

1

2

3

4

5

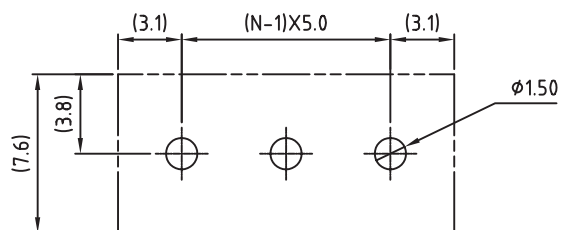
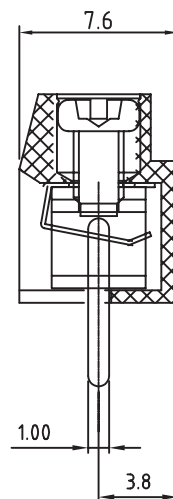
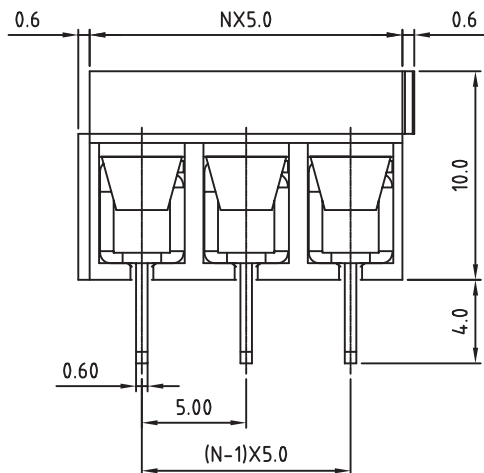
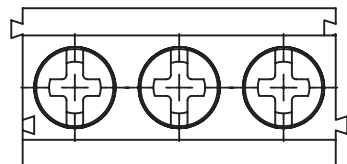

PCB LAYOUT - COMPONENT VIEW

TECHNICAL CHARACTERISTICS

MATERIAL

INSULATOR: PA 66
 FLAMABILITY RATING: UL94-V0
 COLOR: GREEN
 METAL HOUSING: BRASS (CuZn)
 TERMINAL SCREW: STEEL ZINC PLATING "+/-" SLOT TYPE
 WIRE GUARD: STAINLESS STEEL
 SURFACE OF SOLDER TAIL PLATING: TIN

ENVIRONMENTAL

OPERATING TEMPERATURE: -40 UP TO 105°C
 COMPLIANCE: LEAD FREE AND ROHS

ELECTRICAL

UL
 CURRENT RATING: 8A
 WORKING VOLTAGE: 300VAC
 WITHSTANDING VOLTAGE: 1.6KV
 CONTACT RESISTANCE: 20 mOhm MAX

STANDARD

CERTIFIED E315414 / MODEL NUMBER 111

MECHANICAL

SOLID WIRE: 26-14 AWG / 0.13-2.0MM²
 STRANDED WIRE: 26-14 AWG / 0.13-2.0MM²
 TORQUE: 2.6Lb.In / 0.3Nm

WIRE RANGE: WIRE STRIPE LENGTH: 5-6MM
 SCREW: M2.5
 PITCH: 5.0MM

SOLDERING: WAVE PROCESS ONLY

PACKAGING: BOX

SERIE 111

RoHS Compliant

PROJECTION:

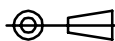

GENERAL TOLERANCE

.X = +/- 0.2

.XX = +/- 0.15



APPROVAL: RJ

UNIT: MM

SCALE:

SHEET: 1/2

DRAW: MARVIN

DESCRIPTION: SERIE 111 - 5.0MM HORIZONTAL ENTRY MODULAR
 WITH PRESSURE CLAMP - 2.0MM² WIRES WR-TBL

WERI PART NO: 691 111 710 0xx

SIZE

A4

G			
F			
E			
D	06-SEP-09	PACKAGING	JC
C	12-OCT-09	STANDARD	JP
B	30-OCT-08	CHARACTERISTICS	JP
A	30-OCT-07	PDF	EC
REV	DATE	FILE	BY

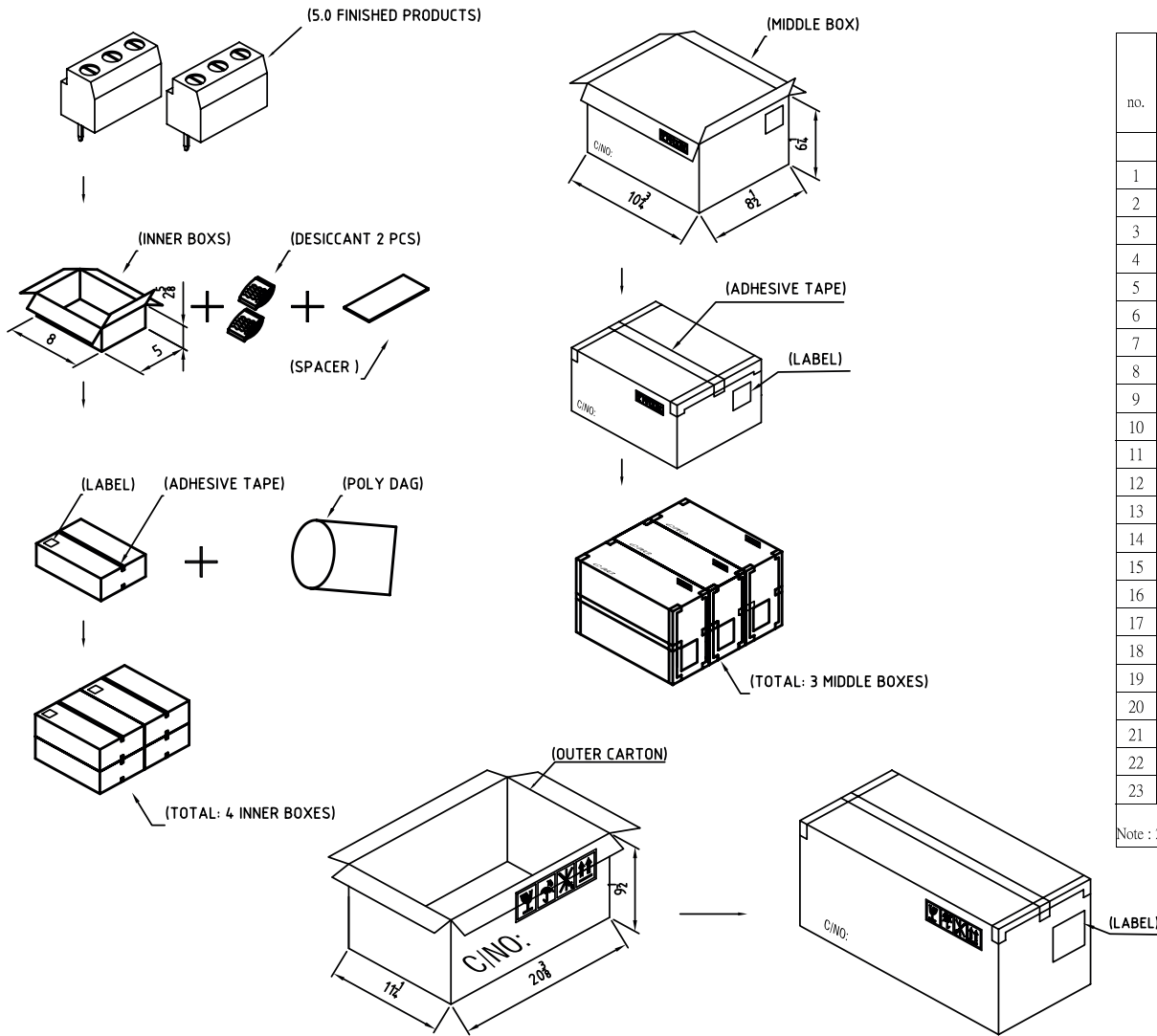

no.	specification	(pcs) inner box quantity	(pcs) middle-carton quantity	(pcs) outer-carton quantity	(pcs) spacer quantity	unit weight (g)			(kg) n/w	(kg) g/w	
						unit	inner box	middle-carton			outer-carton
1	2P	900	3600	10800	0	1.50	53	264	575	16.20	18.20
2	3P	600	2400	7200	0	2.25	53	264	575	16.20	18.20
3	4P	450	1800	5400	0	3.00	53	264	575	16.20	18.20
4	5P	350	1400	4200	6	3.75	53	264	575	15.75	17.75
5	6P	320	1280	3840	6	4.50	53	264	575	17.28	19.28
6	7P	260	1040	3120	6	5.25	53	264	575	16.38	18.38
7	8P	240	960	2880	6	6.00	53	264	575	17.28	19.28
8	9P	210	840	2520	6	6.75	53	264	575	17.01	19.01
9	10P	190	760	2280	6	7.50	53	264	575	17.10	19.10
10	11P	180	720	2160	6	8.25	53	264	575	17.82	19.82
11	12P	160	640	1920	6	9.00	53	264	575	17.28	19.28
12	13P	130	520	1560	6	9.75	53	264	575	15.21	17.21
13	14P	120	480	1440	6	10.50	53	264	575	15.12	17.12
14	15P	120	480	1440	6	11.25	53	264	575	16.20	18.20
15	16P	120	480	1440	6	12.00	53	264	575	17.28	19.28
16	17P	110	440	1320	6	12.75	53	264	575	16.83	18.83
17	18P	110	440	1320	6	13.50	53	264	575	17.82	19.82
18	19P	100	400	1200	6	14.25	53	264	575	17.10	19.10
19	20P	90	360	1080	6	15.00	53	264	575	16.20	18.20
20	21P	90	360	1080	6	15.75	53	264	575	17.01	19.01
21	22P	90	360	1080	6	16.50	53	264	575	17.82	19.82
22	23P	90	360	1080	6	17.25	53	264	575	18.63	20.63
23	24P	90	360	1080	6	18.00	53	264	575	19.44	21.44

Note : 2P-4P be in bulk, above 5P arranged packed. arrange levels=spacers-1.

RoHS Compliant			
G			
F			
E			
D			
C			
B			
A			
REV	DATE	FILE	BY

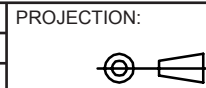

GENERAL TOLERANCE

.X = +/- 0.2

.XX = +/- 0.15



APPROVAL: RJ

UNIT: MM

SCALE:

SHEET: 2/2

DRAW: PEARL

DESCRIPTION: SERIE 111 - 5.0MM HORIZONTAL ENTRY MODULAR WITH PRESSURE CLAMP - 2.0MM² WIRES WR-TBL

WERI PART NO: 691 111 710 0xx_TPK

SIZE

A4

A

B

C

D