

| Description | Material | Finish |
|-------------|----------|--------|
| Body        | Brass    | Nickel |
| Pin         | Brass    | Gold   |
| Insulation  | PTFE     | N/A    |

| REVISIONS |   |           |      |
|-----------|---|-----------|------|
| REV       | DESCRIPTION   | DATE      | APPV |
| B         | Updated footprint and dimensions; Added new title block | 29-JUN-12 | BPM  |

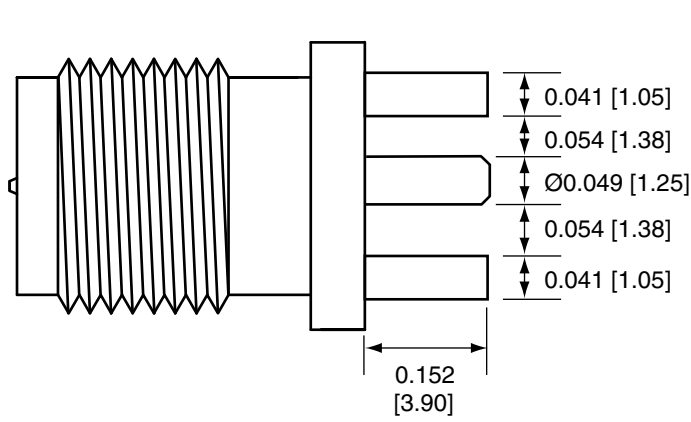

TOP VIEW

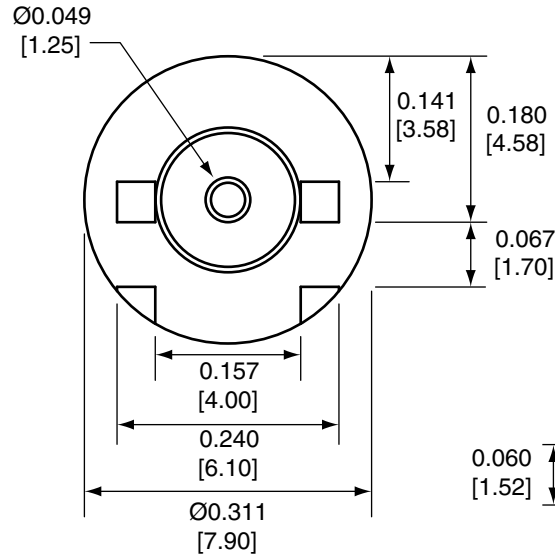

BACK VIEW

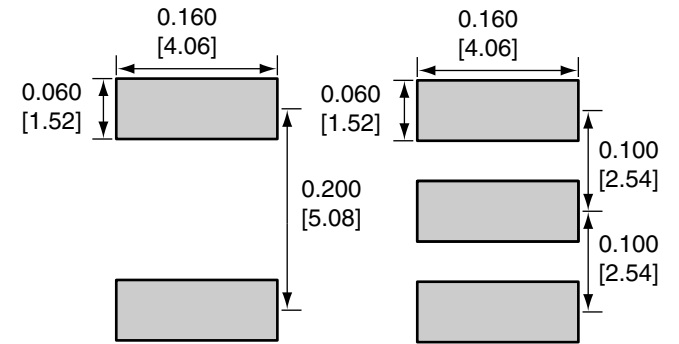
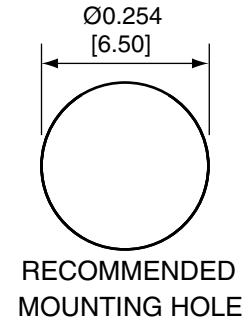

BOTTOM

TOP

RECOMMENDED FOOTPRINT

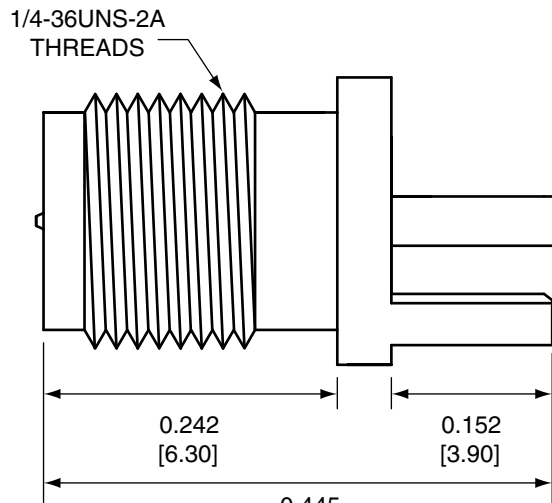



SIDE VIEW

NOTES: (UNLESS OTHERWISE SPECIFIED)

1. ALL DIMENSIONS ARE IN INCHES [mm].
2. DIMENSIONS APPLY AFTER FINISHING.
3. MANUFACTURE TO BE COMPLIANT WITH EU RoHS DIRECTIVE.
4. SAFETY BREAK ALL SHARP CORNERS AND EDGES .02 MAXIMUM.

WARNING: THIS DRAWING CONTAINS PROPRIETARY INFORMATION THAT IS THE SOLE PROPERTY OF LINX TECHNOLOGIES, AND SHALL BE TREATED AS SUCH. NO DISCLOSURE OR REPRODUCTION OF THIS DOCUMENT IS PERMITTED, IN WHOLE OR IN PART, WITHOUT THE EXPRESS WRITTEN PERMISSION OF LINX TECHNOLOGIES OR ITS DESIGNATED AGENTS.

|           |  |   |
|-----------|--|---|
| MATERIAL: | TOLERANCES:<br>.020 [0.50]-.200 [5.00]= ±.008 [0.20]<br>.200 [5.00]-1.200 [30.00]= ±.016 [0.40]<br>1.20 [30.0]-4.75 [120.0]= ±.024 [0.60]<br>4.75 [120.0]-12.40 [315.0]= ±.040 [1.0] | PROJECTION:<br><br>ANGLES: ±1° |
| FINISH:   | DRAWN: B.MURPHY  | DT: 29-JUN-12   |
|           | ENGR: S.HOGAN  | DT: 29-JUN-12   |

|   |                               |                                  |  |
|---|-------------------------------|----------------------------------|--|
|  |                               | 159 ORT LANE<br>MERLIN, OR 97532 |  |
| TITLE:<br>RP-SMA FEMALE EDGE MOUNT<br>FOR 0.062" THICK BOARD                          |                               |                                  |  |
| SIZE<br><b>A</b>  | DWG. NO.<br>CONREV SMA003.062 | REV<br><b>B</b>                  |  |
| SCALE: 2:1  | DO NOT SCALE DRAWING          | SHEET 1 OF 1                     |  |