

# LOW-PROFILE SLIDE SWITCHES

# CUS

RoHS compliant

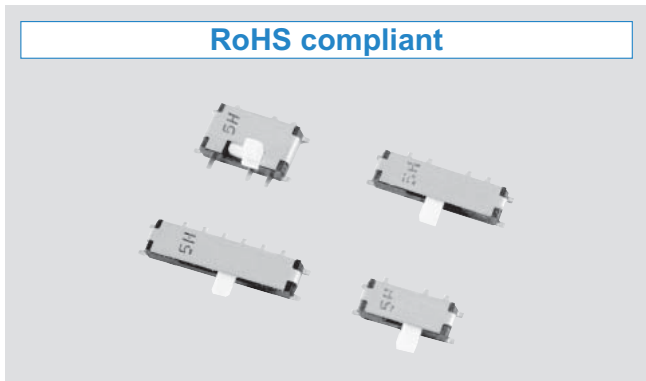

## INTERNAL STRUCTURE

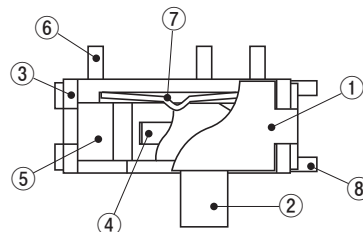

Part name	Material	Flammability
① Cover	Nickel silver	—
② Slider	PA(Polyamide)	UL-94V-0
③ Housing	LCP(Liquid crystal polymer)	
④ Slider contact	Copper alloy, Gold-plated	—
⑤ Fixed contact		
⑥ Terminal pin		
⑦ Click spring	Stainless steel (SUS 301)	—
⑧ Ground terminal	Nickel silver	

## FEATURES

- Low-profile of 1.4 mm
- RoHS compliant

## APPLICATIONS

- Mobile stereo · LCD TV · Camcorder

## PART NUMBER DESIGNATION

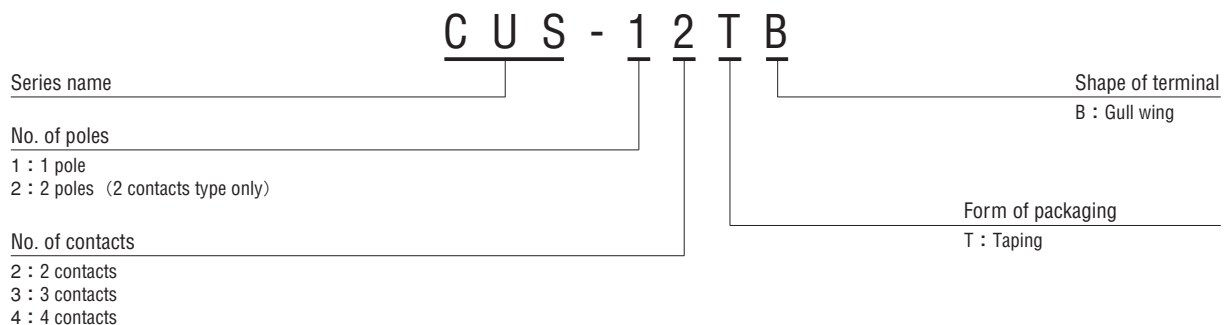

※Please refer to the LIST OF PART NUMBERS when placing orders.

# CUS

## LOW-PROFILE SLIDE SWITCHES

### LIST OF PART NUMBERS

Schematic	No. of contacts	Shape of terminal	Form of packaging	Part number	Pieces in package
1	2	B (Gull wing)	Taping	CUS-12TB	2500 pcs./reel
	3			CUS-13TB	
	4			CUS-14TB	
2	CUS-22TB			1400 pcs./reel	

### STANDARD SPECIFICATIONS

Operating temp. range	- 20 ~ 70 °C
Storage temp. range	- 40 ~ 85 °C
Sealing	Non washable
Net weight	Approx. 0.08 g (CUS-12) Approx. 0.10 g (CUS-13) Approx. 0.13 g (CUS-14) Approx. 0.11 g (CUS-22)

### MECHANICAL CHARACTERISTICS

No. of positions	2, 3, 4	
Stroke	1.5 mm	
Operating force	CUS-12 <sup>※1</sup>	2 ± 1.7 N {0.2 ± 0.17 kgf}
	CUS-13 <sup>※2</sup>	A → B : 1.5 ± 1.2 N {0.15 ± 0.12 kgf}
		B → C : 2 ± 1.7 N {0.2 ± 0.17 kgf}
		C → B : 1.5 ± 1.2 N {0.15 ± 0.12 kgf}
	CUS-14 <sup>※3</sup>	A → B : 1.5 ± 1.2 N {0.15 ± 0.12 kgf}
		B → C : 2 ± 1.7 N {0.2 ± 0.17 kgf}
		C → D : 2 ± 1.7 N {0.2 ± 0.17 kgf}
		D → C : 1.5 ± 1.2 N {0.15 ± 0.12 kgf}
B → A : 2 ± 1.7 N {0.2 ± 0.17 kgf}		
CUS-22 <sup>※4</sup>	2 ± 1.7 N {0.2 ± 0.17 kgf}	
Stop strength	10 N {1.02 kgf} 15 s	
Solderability	245 ± 3 °C 2 ~ 3 s	
Soldering heat	Reflow peak : 250 ~ 255 °C	
	Manual soldering : 350 ± 10 °C 3 ~ 4 s	
Shear	5 N {0.5 kgf} 10 s	
Substrate bending	Width 90 mm, bend 3 mm, 5 s, 1 time	
Pull-off strength	5 N {0.5 kgf} 10 s	

{ } : Reference only

### ELECTRICAL CHARACTERISTICS

Contact rating	DC50 V 100 mA
Non-switching	DC4 V 300 mA
Switching	DC20 mV 1 μA
Minimum	
Contact timing	Non-shorting
Contact resistance	70 mΩ maximum
Insulation resistance	100 MΩ minimum (DC 100 V)
Dielectric strength	AC100 V 60 s

### ENVIRONMENTAL CHARACTERISTICS

Vibration	Amplitude 1.5 mm or Acceleration 98 m/s <sup>2</sup> , 10-500-10 Hz, 3 directions for 10 cycles each
Shock	490 m/s <sup>2</sup> , 11 ms, 6 directions for 3 times each
Load life	Continuous load 10000 cycles, DC4 ± 0.5 V, 300 ± 10 mA
Humidity	40 °C, Relative humidity 90 ~ 95 %, 240 h, No load
High temp. exposure	85 °C, 96 h, No load
Low temp. exposure	-40 °C, 96 h, No load
Thermal shock	-40 (0.5 h) ~ 85 °C (0.5 h), 5 cycles

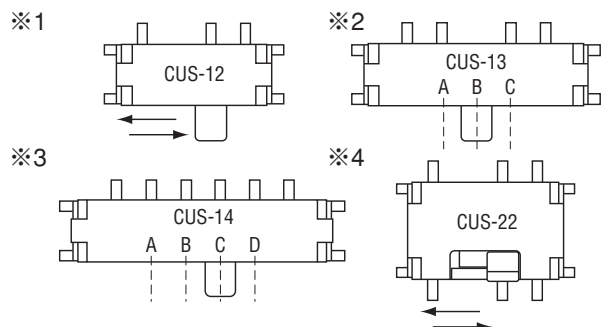

# CUS LOW-PROFILE SLIDE SWITCHES

## OUTLINE DIMENSIONS

Unless otherwise specified, tolerance : ± 0.2 (Unit : mm)

### ● CUS-12B

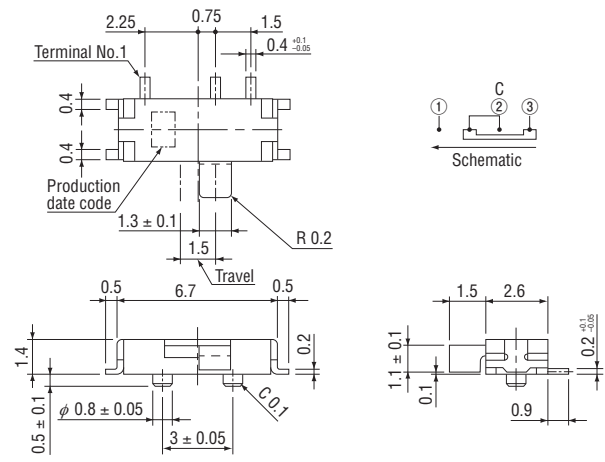

### ● CUS-13B

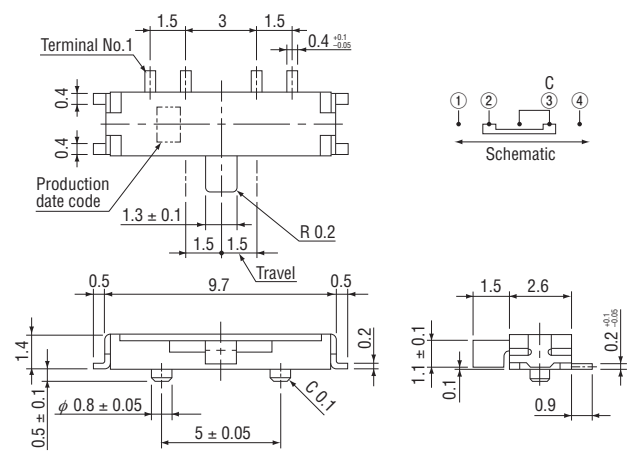

### ● CUS-14B

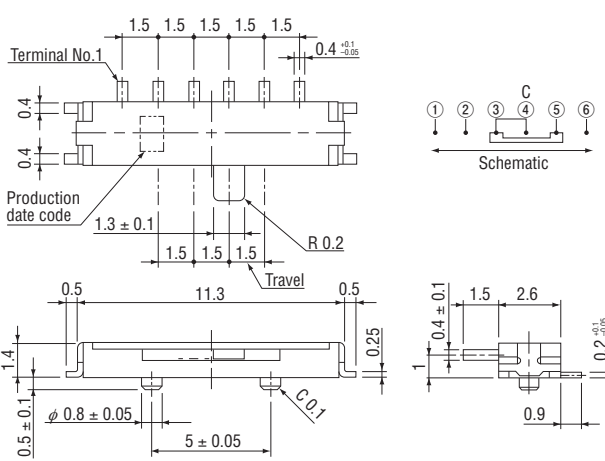

### ● CUS-22B

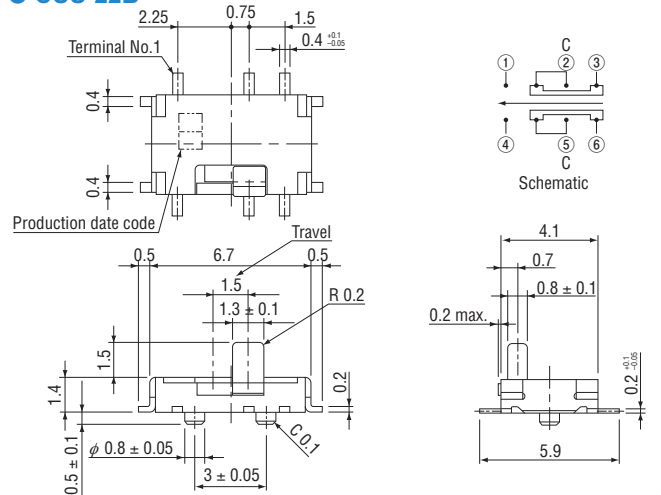

## RECOMMENDED P.C.B. PAD OUTLINE DIMENSIONS

(Unit : mm)

### ● CUS-12B

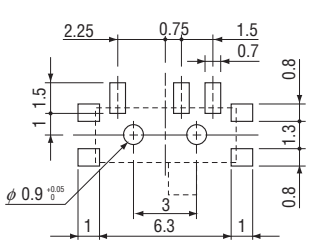

### ● CUS-13B

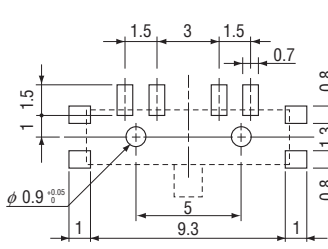

### ● CUS-14B

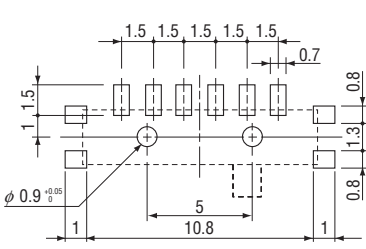

### ● CUS-22B

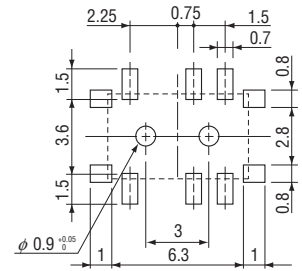

# CUS LOW-PROFILE SLIDE SWITCHES

## PACKAGING SPECIFICATIONS

Taping version is packaged in 2500 pcs. per reel (1400 pcs. for CUS-22).

Taping version is boxed with 1 reel (2500 pcs. or 1400 pcs.).  
 Maximum number of consecutive missing pieces = 2. Leader length and reel dimension are shown in the diagrams below.

### Embossed tape dimensions

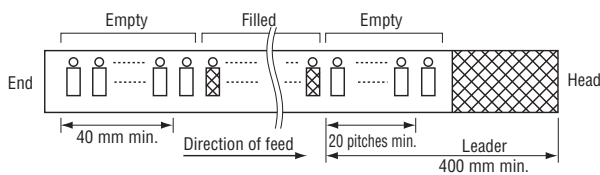

### CUS-12TB

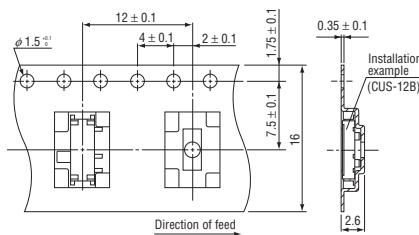

### CUS-13TB, CUS-14TB

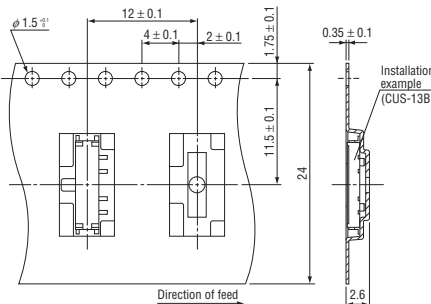

### CUS-22TB

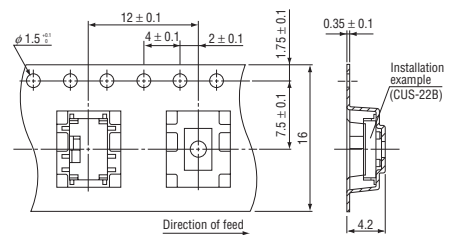

### Reel dimensions

(Unit: mm)

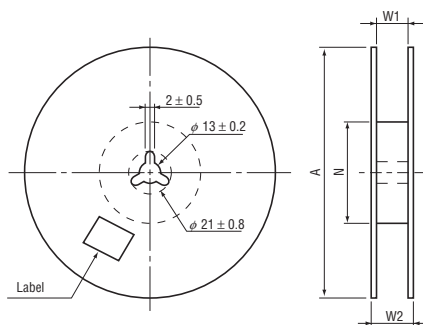

Part number	A	W <sub>1</sub>	W <sub>2</sub>	N
12TB, 22TB	$\phi 330 \pm 2$	$17.4 \pm 1$	$21.4 \pm 1$	$\phi 80 \pm 1$
13TB, 14TB	$\phi 330 \pm 2$	$25.4 \pm 1$	$29.4 \pm 1$	$\phi 80 \pm 1$