



SERIES 300A SWITCHES

ROCKER AND PADDLE SWITCHES - MINIATURE

TACT SWITCHES

NAVIGATION SWITCHES

PUSHBUTTON SWITCHES

TOGGLE SWITCHES

ROCKER SWITCHES

SLIDE SWITCHES

SNAP-ACTION SWITCHES

DIP SWITCHES

KEYLOCK SWITCHES

ROTARY SWITCHES

DETECTOR SWITCHES

CAP OPTIONS

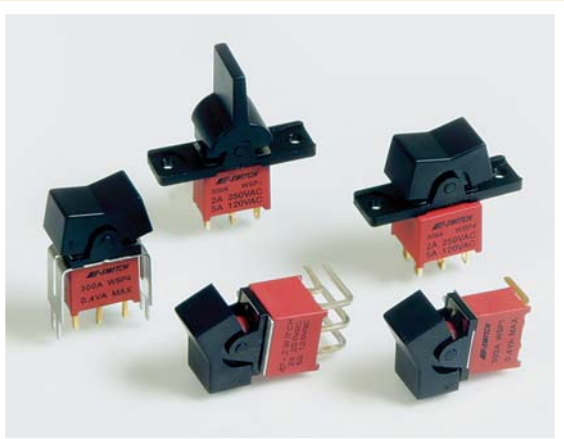

FEATURES & BENEFITS

- ▶ Multiple rocker & paddle options
- ▶ Multiple termination options
- ▶ Sealed to IP67

APPLICATIONS/MARKETS

- ▶ Telecommunications
- ▶ Instrumentation
- ▶ Test equipment
- ▶ Networking
- ▶ Computer peripherals

SPECIFICATIONS

Contact Rating:	Dependent upon contact material
Life Expectancy:	30,000 make-and-break cycles at full load
Contact Resistance:	10 mΩ typ. initial @ 2-4 V DC, 100 mA for both silver and gold plated contacts
Insulation Resistance:	1,000 MΩ 1min.
Dielectric Strength:	1,000 V RMS @ sea level
Operating Temperature:	-30° C to 85° C

MATERIALS

Housing:	Glass filled nylon, flame retardant, heat stabilized (UL 94-V0).
Actuator:	Nylon, black std. (UL 94-HB)
Actuator Seal:	Internal O-Ring
Switch Support:	Brass or steel, tin plated
Actuator Pivot & Mounting Bracket:	Nylon (UL 94-HB)
Actuator Pivot Retainer:	Stainless steel
Contacts / Terminals:	Silver or gold plated copper alloy
Terminal Seal:	Epoxy



HOW TO ORDER

SERIES	MODEL NO.	ACTUATOR	COLOR	TERMINATION	CONTACT MATERIAL	SEAL
300A	□ □ □ □ □	□ □ □ □ □	□ □ □	□ □	□	E
	WSP1 WSP2 WSP3 WSP4 WSP5 WDP1 WDP2 WDP3 WDP4 WDP5	<u>Panel Mount:</u> R1 R2 R11 R16	BLK =Black RED =Red WHT=White	M1 M3	Q = Silver R = Gold	E = Epoxy Sealed at Base of Terminal
	(See Above Model No. Options)	<u>P.C. Mount:</u> J1 J2 J3 J4 J5 J6	BLK =Black RED =Red WHT=White	M2 M6 M7 VS2 VS3 M61 M71 VS21	Q = Silver R = Gold	E = Epoxy Sealed at Base of Terminal



Example Ordering Number

300A-WSP5-R11-WHT-M1-Q-E

Specifications subject to change without notice.

Actuator & Frame Colors:

Black, White, Red

Consult E-Switch for other colors and custom actuator marking.



MODEL NUMBER OPTIONS

SPDT

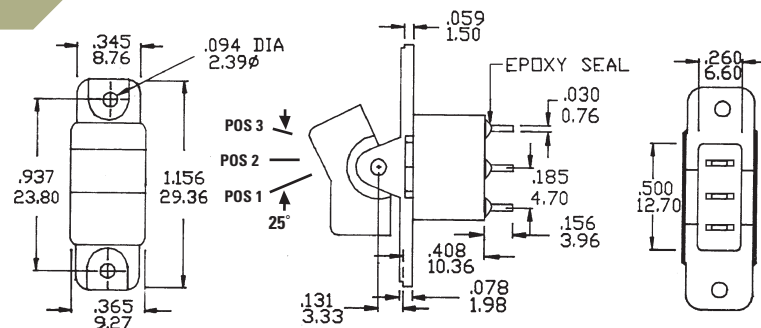
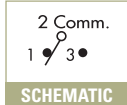

Model No.	POS 1	POS 2	POS 3
WSP-1	ON	NONE	ON
WSP-2	ON	NONE	(ON)
WSP-3	ON	OFF	ON
WSP-4	(ON)	OFF	(ON)
WSP-5	ON	OFF	(ON)
Term. Comm.	2-3	OPEN	2-1

() = Momentary

DPDT

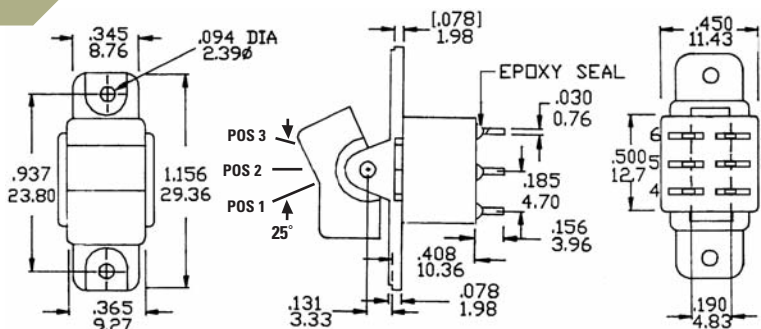
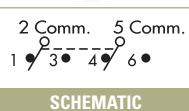

Model No.	POS 1	POS 2	POS 3
WDP-1	ON	NONE	ON
WDP-2	ON	NONE	(ON)
WDP-3	ON	OFF	ON
WDP-4	(ON)	OFF	(ON)
WDP-5	ON	OFF	(ON)
Term. Comm.	2-3, 5-6	OPEN	2-1, 5-4

() = Momentary

ACTUATOR OPTIONS – PANEL MOUNT

R1

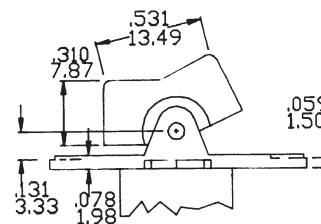
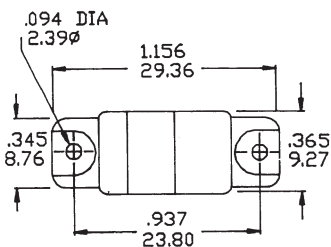

R2

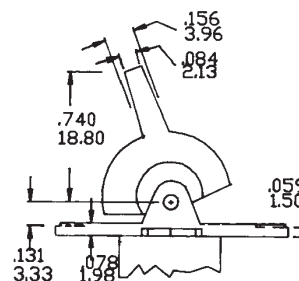
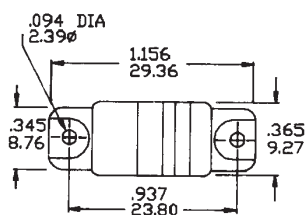



SERIES 300A SWITCHES

ROCKER AND PADDLE SWITCHES - MINIATURE

TACT SWITCHES

NAVIGATION SWITCHES

PUSHBUTTON SWITCHES

TOGGLE SWITCHES

ROCKER SWITCHES

SLIDE SWITCHES

SNAP-ACTION SWITCHES

DIP SWITCHES

KEYLOCK SWITCHES

ROTARY SWITCHES

DETECTOR SWITCHES

CAP OPTIONS

R11

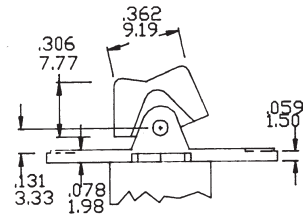
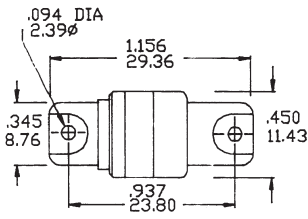

R16

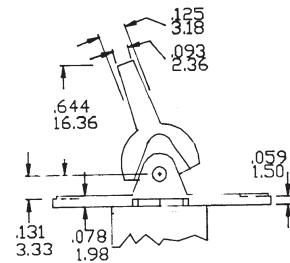
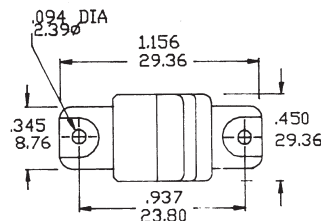

ACTUATOR OPTIONS - P.C. MOUNT

J1

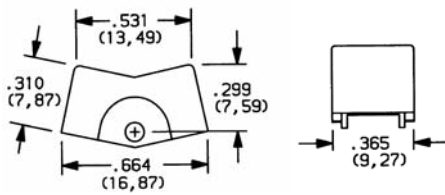

J2

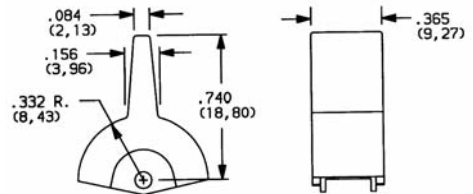

J3

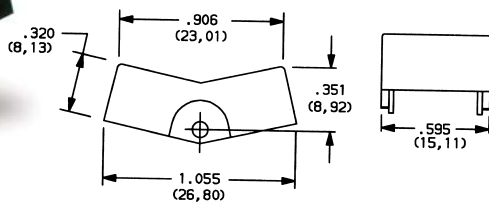
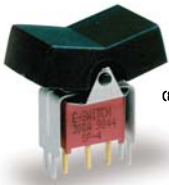

J4

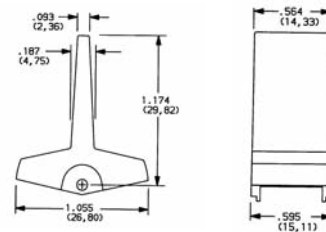

J5

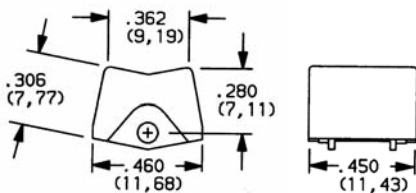

J6

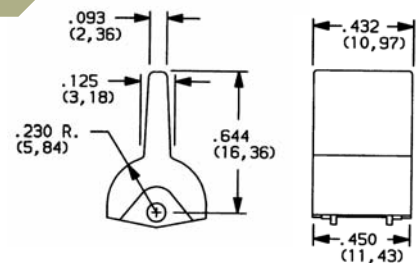



TERMINATION OPTIONS – PANEL MOUNT

M1

STD

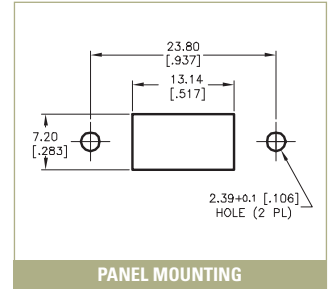
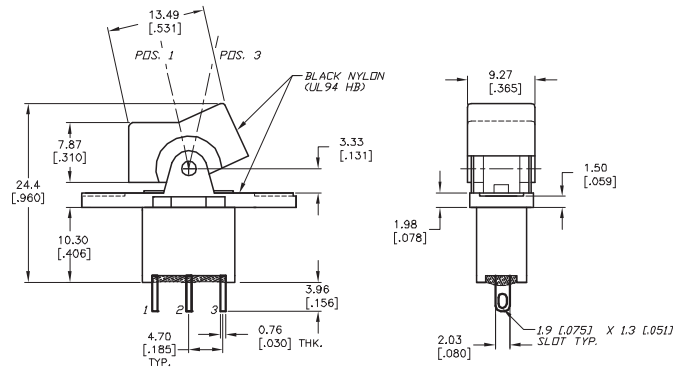

M3

QUICK CONNECT

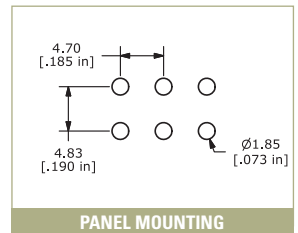
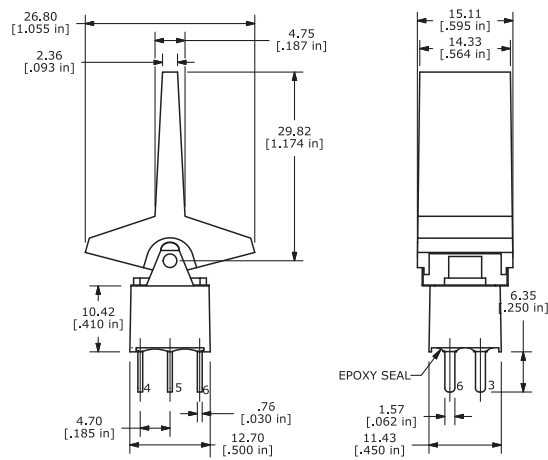

TERMINATION OPTIONS – P.C. MOUNT

M2

STD

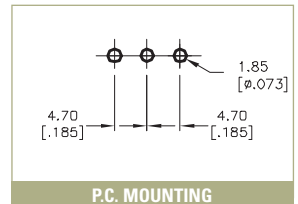
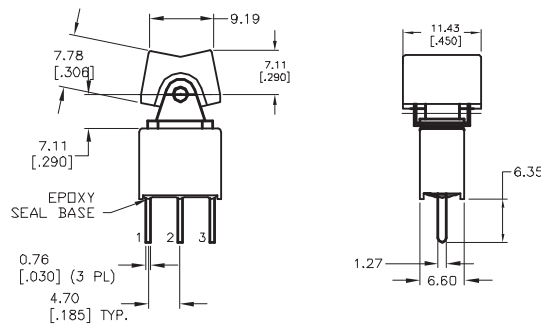

M6

SPDT

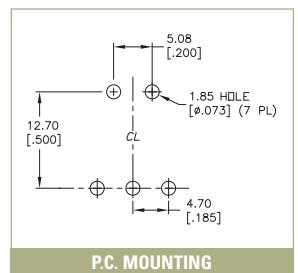
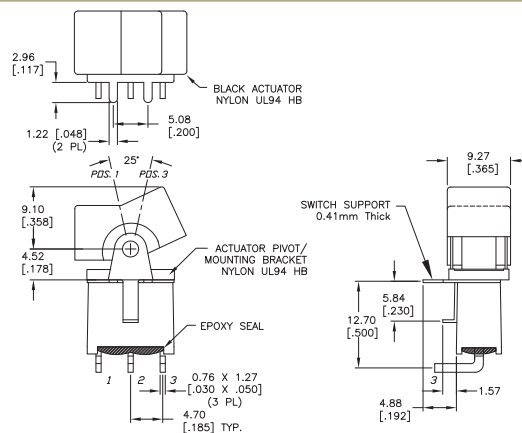



SERIES 300A SWITCHES

ROCKER AND PADDLE SWITCHES - MINIATURE

TACT SWITCHES

NAVIGATION SWITCHES

PUSHBUTTON SWITCHES

TOGGLE SWITCHES

ROCKER SWITCHES

SLIDE SWITCHES

SNAP-ACTION SWITCHES

DIP SWITCHES

KEYLOCK SWITCHES

ROTARY SWITCHES

DETECTOR SWITCHES

CAP OPTIONS

M6

DPDT

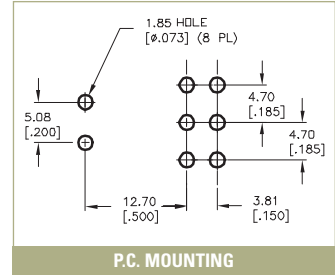
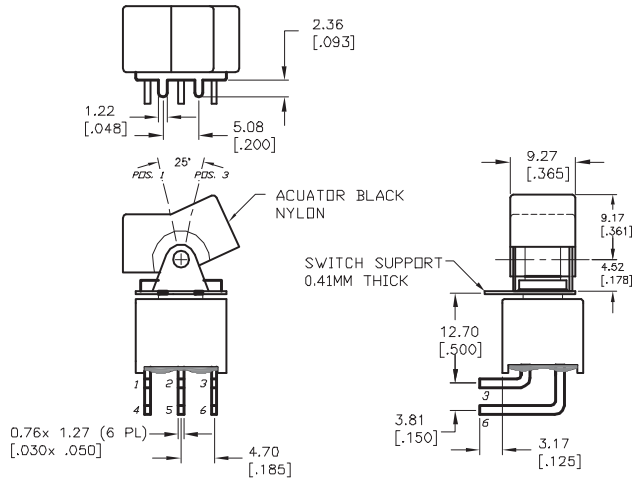

M7

SPDT

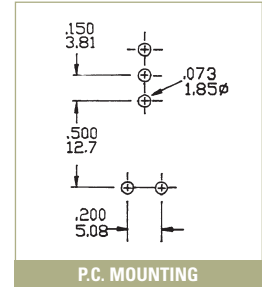
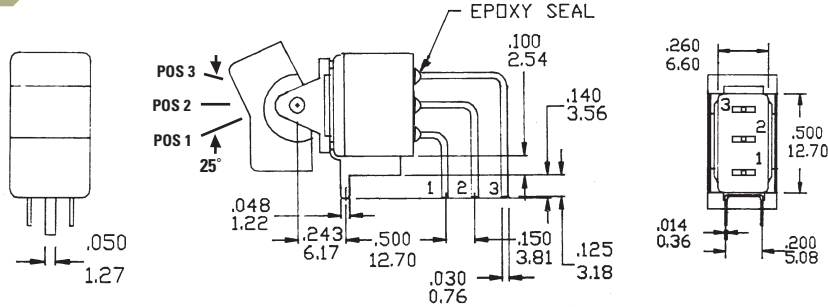

M7

DPDT

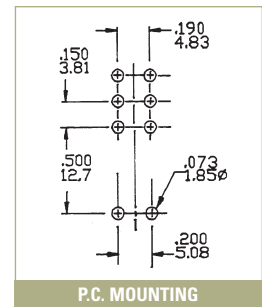
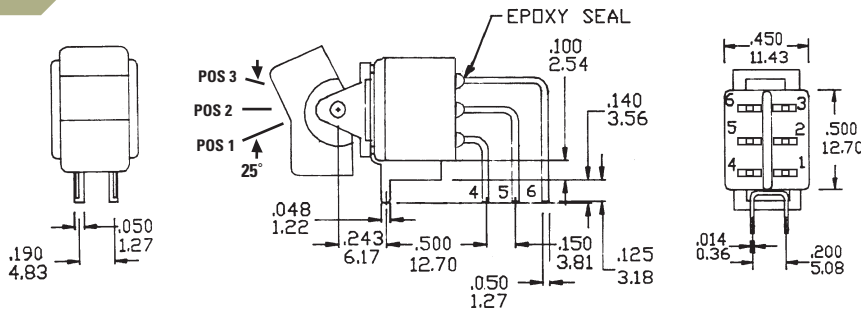

M71

SPDT

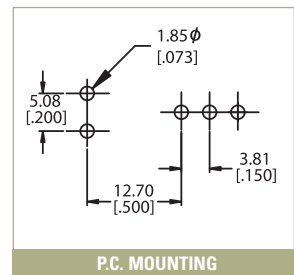
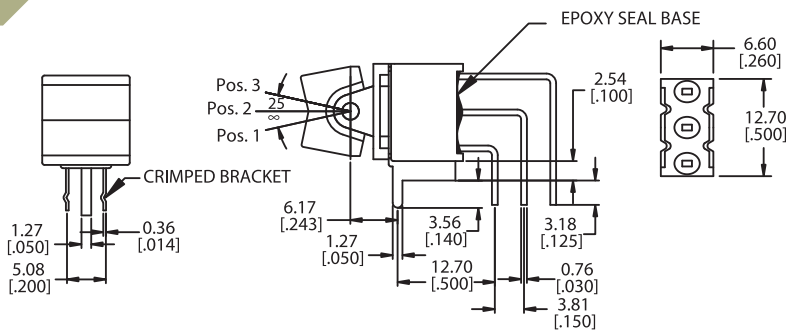



M71

DPDT

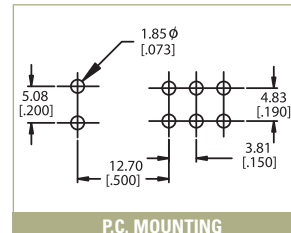
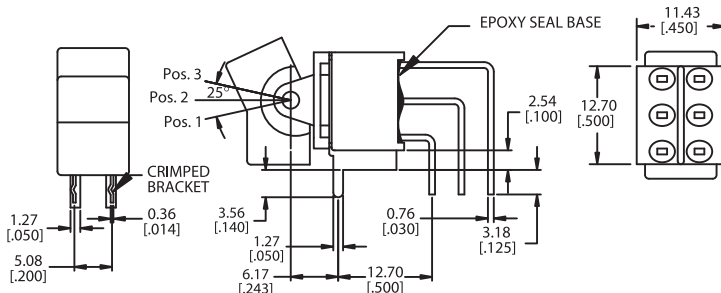

VS2-VS3

SPDT

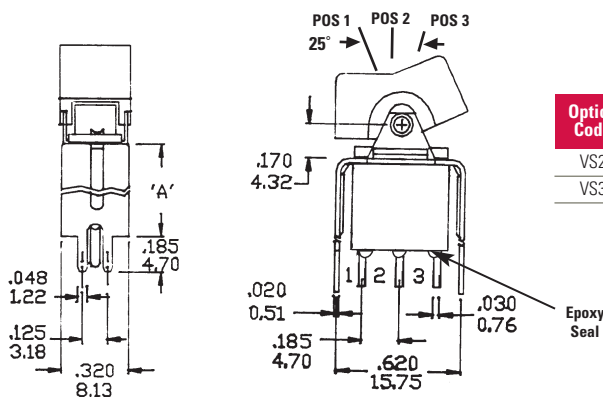

Option Code	Dim. 'A'
VS2	.460 (11.68)
VS3	.630 (16.00)

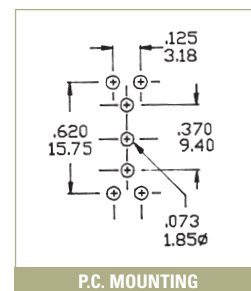

VS2-VS3

DPDT

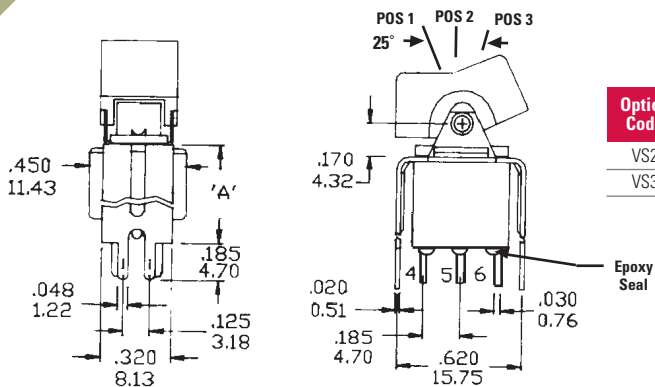

Option Code	Dim. 'A'
VS2	.460 (11.68)
VS3	.630 (16.00)

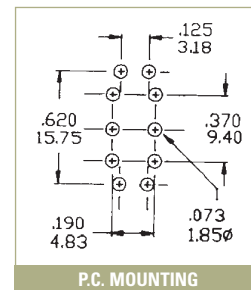

CONTACT MATERIAL OPTIONS

Q

Fixed Terminal:	Gold flash over silver plated copper alloy
Moving Contact:	Silver plated copper alloy
Rating:	5 Amps with resistive load @ 120VAC or 28VDC; 2 Amps with resistive load @ 250VAC

R

Fixed Terminal:	Copper alloy with gold plate over nickel plate
Moving Contact:	Copper alloy with gold plate overnickel plate
Rating:	0.4 Volt-Amps (VA) max. @ 20V max. (AC or DC)