

ASA (6W) Isolated DC/DC Converter Module
Industry Standard Size, 1.25"x0.8"x0.4"
9-36V/18-75V Inputs, 3.3V/5V/±5V/12V/±12V/15V/±15V Outputs

The ASA (6W) Isolated DC/DC Converter is Astec's 4:1 wide input voltage family for low power applications. With efficiency up to 81% typical for 5V module, this product is allowed to work at operating temperature range from -40°C to 71°C and a wide input voltage range of 4:1. Single-output models and dual-output models are available for a wide range of applications in telecommunication, transportation equipment, etc.. Housed in small package, 1.25"x0.8"x0.4", with industry standard pinout, 24-pin DIP, ASA family eases the PCB designs and mechanical designs of customers' end products.



Industry Standard Size
1.25" x0.80" x 0.40"

Special Features

- Wide 4 : 1 input range
- High efficiency, 81%@5V
- -40°C to 90°C case surface operating temperature
- Input / Output isolation 1.5KVdc
- Low output ripple and noise
- Shielded metal case with size (1.25"x0.8"x0.4")
- Industrial standard pinout (24-pin DIP)
- Lead-free soldering pins
- Fixed switching frequency (200KHz)

Environmental Specifications

- Operating temperature: -40°C to +71°C
- Storage temperature: -55°C to +105°C
- MTBF: >1 million hours
- ROHS Compliant



Electrical Parameters

Input

Input range	9-36 VDC; 18-75 VDC
Efficiency	81%@ 5V (Typical)

Output

Regulation (Line, Load, Temp)	<2%
Ripple and noise	2% typical (100mV p-p max@ 5V)
Transient Response	6% max deviation with 50% load to full load 250uS (max) recovery
Short Circuit Protection	Indefinite

Safety

Designed to meet EN60950 (up to SELV limit)



Technical Reference Note ASA (6W) Family



ASA (6W) SERIES

THIS SPECIFICATION COVERS THE REQUIREMENTS
FOR AN INDUSTRY STANDARD PACKAGE OF 1.25"x0.8"x0.4", 4:1 INPUT RANGE,
4-6W, SINGLE OUTPUT AND DUAL OUTPUT ISOLATED DC/DC CONVERTER

PART NUMBERS

MODEL NAME / SIS CODE	Nominal Vin / Range of Vin	Vout / Iout
ASA01F18-L	24V / 9-36V	3.3V / 1.2A
ASA01A18-L	24V / 9-36V	5V / 1A
ASA00AA18-L	24V / 9-36V	±5V / ±0.5A
ASA00B18-L	24V / 9-36V	12V / 0.5A
ASA00BB18-L	24V / 9-36V	±12V / ±0.25A
ASA00C18-L	24V / 9-36V	15V / 0.4A
ASA00CC18-L	24V / 9-36V	±15V / ±0.2A
ASA01F36-L	48V / 18-75V	3.3V / 1.2A
ASA01A36-L	48V / 18-75V	5V / 1A
ASA01AA36-L	48V / 18-75V	±5V / ±0.5A
ASA00B36-L	48V / 18-75V	12V / 0.5A
ASA00BB36-L	48V / 18-75V	±12V / ±0.25A
ASA00C36-L	48V / 18-75V	15V / 0.4A
ASA00CC36-L	48V / 18-75V	±15V / ±0.2A



Technical Reference Note ASA (6W) Family



ELECTRICAL SPECIFICATIONS

Unless otherwise indicated, specifications apply over all operating input voltage and temperature conditions.
Standard test condition on a single unit.

Tambient :	25°C
+Vin :	24V $\pm 2\%$ (ASAxxxx18-L) 48V $\pm 2\%$ (ASAxxxx36-L)
-Vin :	return pin for +Vin
+Vout :	connect to load
-Vout :	connect to load (return)

ABSOLUTE MAXIMUM RATINGS

Stresses in excess of the absolute maximum ratings can cause permanent damage to the device. These are absolute stress ratings only. Functional operation of the device is not implied at these or any other conditions in excess of those given in the operational sections of the IPS. Exposure to absolute maximum ratings for extended periods can adversely affect device reliability.

Parameter	Device	Symbol	Min	Typ	Max	Unit
a) Input Voltage:						
Continuous:	ASAxxxx18-L	V_I	0	-	36	Vdc
Transient (100ms)	ASAxxxx18-L	$V_{I,trans}$	0	-	50	Vdc
Continuous:	ASAxxxx36-L	V_I	0	-	75	Vdc
Transient (100ms)	ASAxxxx36-L	$V_{I,trans}$	0	-	100	Vdc
b) Operating Temperature						
Ambient	All	T_a	-40	-	71	°C
Case Surface		T_c	-40	-	90	°C
c) Storage Temperature	All	T_{STG}	-55	-	105	°C
d) Operating Humidity	All	-	-	-	95	%
e) I/O Isolation (Conditions : 0.5mA for 60 sec) Input-Output	All	-	-	-	1500	Vdc
f) Output Power	3.3V	$P_{o,max}$	-	-	4	W
	5V / $\pm 5V$	$P_{o,max}$	-	-	5	W
	12V / $\pm 12V$	$P_{o,max}$	-	-	6	W
	15V / $\pm 15V$	$P_{o,max}$	-	-	6	W



Technical Reference Note ASA (6W) Family



INPUT SPECIFICATIONS

Parameter	Device	Symbol	Min	Typ	Max	Unit	
a) Operating Input Voltage	ASAxXXX18-L	V_I	9	24	36	V_{DC}	
	ASAxXXX36-L	V_I	18	48	75	V_{DC}	
b) Maximum Input Current ASAxXXX18-L ($V_I = 0$ to $V_{I,max}$: $I_o = I_{o,max}$)	3.3V	$I_{I,max}$	-	-	700	mA	
	5V / $\pm 5V$	$I_{I,max}$	-	-	800	mA	
	12V / $\pm 12V$	$I_{I,max}$	-	-	950	mA	
	15V / $\pm 15V$	$I_{I,max}$	-	-	950	mA	
	ASAxXXX36-L ($V_I = 0$ to $V_{I,max}$: $I_o = I_{o,max}$)	3.3V	$I_{I,max}$	-	-	350	mA
		5V / $\pm 5V$	$I_{I,max}$	-	-	400	mA
		12V / $\pm 12V$	$I_{I,max}$	-	-	500	mA
		15V / $\pm 15V$	$I_{I,max}$	-	-	500	mA
c) No Load Input Power ($V_I = V_{I,nom}$)	All	-	-	-	0.4	W	

CAUTION: This power module is not internally fused. An input fuse must always be used.



Technical Reference Note ASA (6W) Family



OUTPUT SPECIFICATIONS

Parameter	Device	Symbol	Min	Typ	Max	Unit	
a) Output Voltage Setpoint ($V_1 = V_{1,min}$ to $V_{1,max}$; $I_o = I_{o,max}$; $T_A = 25^\circ\text{C}$)	3.3V	$V_{o,set}$	3.23	3.30	3.37	V_{dc}	
	5V	$V_{o,set}$	4.90	5.00	5.10	V_{dc}	
	12V	$V_{o,set}$	11.76	12.00	12.24	V_{dc}	
	15V	$V_{o,set}$	14.70	15.00	15.30	V_{dc}	
	$\pm 5V$	$V_{o,set}$	± 4.90	± 5.00	± 5.10	V_{dc}	
	$\pm 12V$	$V_{o,set}$	± 11.76	± 12.00	± 12.24	V_{dc}	
	$\pm 15V$	$V_{o,set}$	± 14.70	± 15.00	± 15.30	V_{dc}	
b) Output Regulation: Line ($V_1 = V_{1,max}$ to $V_{1,min}$; $I_o = I_{o,max}$)	All	-	-	-	0.5	%	
	Load ($V_1 = V_{1,nom}$; $I_o = I_{o,min}$ to $I_{o,max}$)	3.3V	-	-	-	1	%
		Others	-	-	-	0.5	%
	Cross ($V_1 = V_{1,nom}$; $I_o = +I_{o,max}, -I_{o,min}$ or $+I_{o,min}, -I_{o,max}$ to $+I_{o,max}, -I_{o,max}$)	$\pm 5V/\pm 12V/\pm 15V$	-	-	-	3	%
	Temperature ($T_c = -40^\circ\text{C}$ to $+90^\circ\text{C}$)	All	-	-	-	1.0	% V_o
c) Output Ripple and Noise (Across $1\mu\text{F}$ @50V, X7R ceramic capacitor & $10\mu\text{F}$ @25V tantalum capacitor) See Figure 1. Peak-to-Peak (5 Hz to 20 MHz)	3.3V	-	-	-	100	mVp-p	
	5V	-	-	-	100	mVp-p	
	12V	-	-	-	120	mVp-p	
	15V	-	-	-	150	mVp-p	
d) Rated Output Current Single Output	3.3V	I_o	120	-	1200	mA	
	5V	I_o	100	-	1000	mA	
	12V	I_o	50	-	500	mA	
	15V	I_o	40	-	400	mA	
	Dual Output	$\pm 5V$	I_o	± 50	-	± 500	mA
		$\pm 12V$	I_o	± 25	-	± 250	mA
		$\pm 15V$	I_o	± 20	-	± 200	mA
e) Efficiency ($V_1 = V_{1,nom}$; $I_o = I_{o,max}$; $T_A = 25^\circ\text{C}$)	3.3V	-	-	78	-	%	
	5V	-	-	81	-	%	
	12V	-	-	82	-	%	
	15V	-	-	83	-	%	
	$\pm 5V$	-	-	81	-	%	
	$\pm 12V$	-	-	82	-	%	
	$\pm 15V$	-	-	83	-	%	
f) Switching Frequency	All	-	180	200	220	KHz	



Technical Reference Note ASA (6W) Family



OUTPUT SPECIFICATIONS (Cont.)

Parameter	Device (Series)	Symbol	Min	Typ	Max	Unit
g) Dynamic Response : ($\Delta I_o/\Delta t = 0.08A/\mu s$; $V_i = V_{I,nom}$; $T_A = 25^\circ C$)						
Load Change from $I_o = 50\%$ to 100% of $I_{o,max}$:	3.3V/5V/ $\pm 5V$	-	-	-	6	%Vo
Peak Deviation Settling Time (to $V_{o,nom}$)	12V/ $\pm 12V$ / 15V/ $\pm 15V$	-	-	-	2	%Vo
	All	-	-	-	250	μsec
i) Output Voltage Overshoot ($I_o = I_{o,max}$; $T_A = 25^\circ C$)						
	All	-	-	0	4	%Vo

FEATURE SPECIFICATIONS

Parameter	Device (Series)	Symbol	Min	Typ	Max	Unit
Undervoltage Lockout						
Turn-on Point ($I_o = I_{o,max}$)	ASAxxxx18-L	-	-	8.4	8.9	V
	ASAxxxx36-L	-	-	9.4	16	V
Turn-off Point ($I_o = I_{o,max}$)						
	ASAxxxx18-L	-	-	5		V
	ASAxxxx36-L	-	-	8		V
Isolation Capacitance	All	-	-	1000	-	PF
Isolation Resistance	All	-	10	-	-	M Ω
Calculated MTBF ($I_o = I_{o,max}$; $T_A = 25^\circ C$)	All	-	1M	-	-	Hours
Weight	All	-	-	-	20	g



Technical Reference Note ASA (6W) Family



MAXIMUM CAPACITIVE LOAD

Astec Model Number	Maximum Capacitive Load @ Full Load		Full Load
	Vin = Low Line	Vin = Nominal Line	
ASA01F18	200uF	320uF	1.2A
ASA01F36	590uF	540uF	1.2A
ASA01A18	200uF	310uF	1A
ASA01A36	300uF	320uF	1A
ASA00B18	200uF	240uF	0.5A
ASA00B36	110uF	120uF	0.5A
ASA00C18	80uF	120uF	0.4A
ASA00C36	75uF	75uF	0.4A
ASA00AA18	±200uF	±300uF	±0.5A
ASA00AA36	±400uF	±440uF	±0.5A
ASA00BB18	±80uF	±120uF	±0.25A
ASA00BB36	±50uF	±70uF	±0.25A
ASA00CC18	±50uF	±45uF	±0.2
ASA00CC36	±80uF	±90uF	±0.2



Technical Reference Note ASA (6W) Family



Basic Operation and Features

The ASA converters were designed specifically to address applications where high power density is required. These modules provide 1500V isolation and operate from the input ranges of 9V-36V and 18V-75V with standard features such as short circuit protection.

Output Current Protection

To provide protection in a short circuit condition, the converter is equipped with current limiting circuitry and can endure the fault condition for an unlimited duration. At the point of current-limit inception, the converter goes into "Hiccup Mode", causing the output current to be limited both in peak and duration. The converter operates normally once the output current is brought back into its specified range.

TEST SETUP

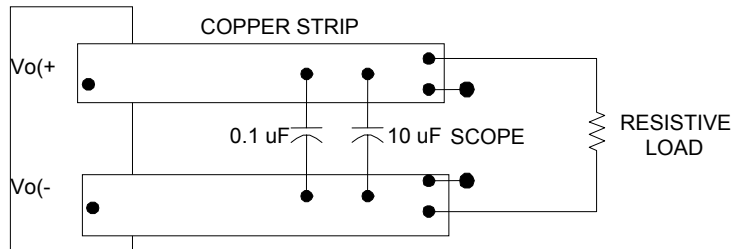

Note: Use a 0.1 μ F @50V X7R ceramic capacitor and a 10 μ F @ 25V tantalum capacitor. Scope measurement should be made using a BNC socket. Position the load between 51 mm and 76 mm (2 in. and 3 in.) from module.

Figure 1 : Peak-to-Peak Output Noise Measurement Test Setup.

Performance Curves – Efficiency Curve

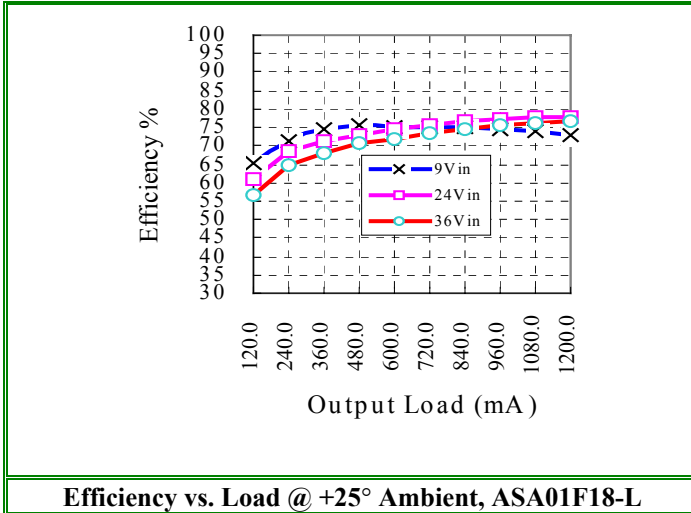

Efficiency vs. Load @ +25° Ambient, ASA01F18-L

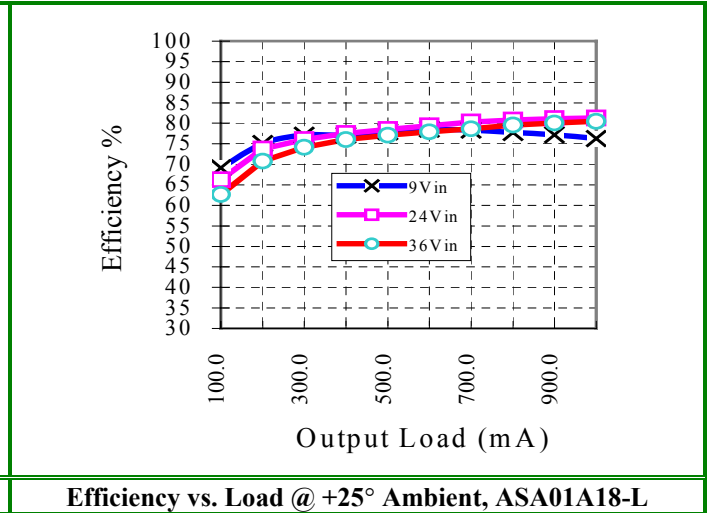

Efficiency vs. Load @ +25° Ambient, ASA01A18-L

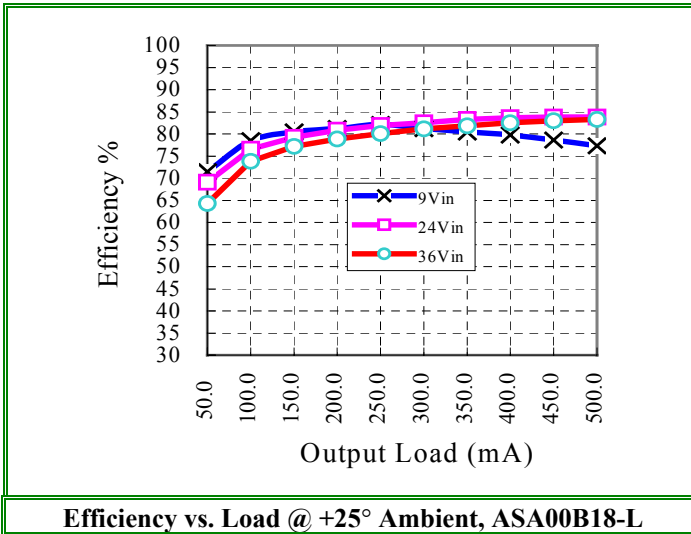

Efficiency vs. Load @ +25° Ambient, ASA00B18-L

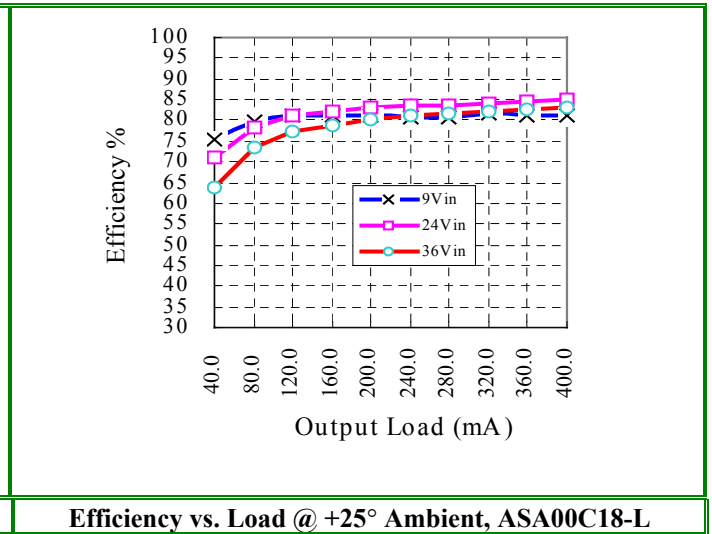

Efficiency vs. Load @ +25° Ambient, ASA00C18-L



Technical Reference Note ASA (6W) Family

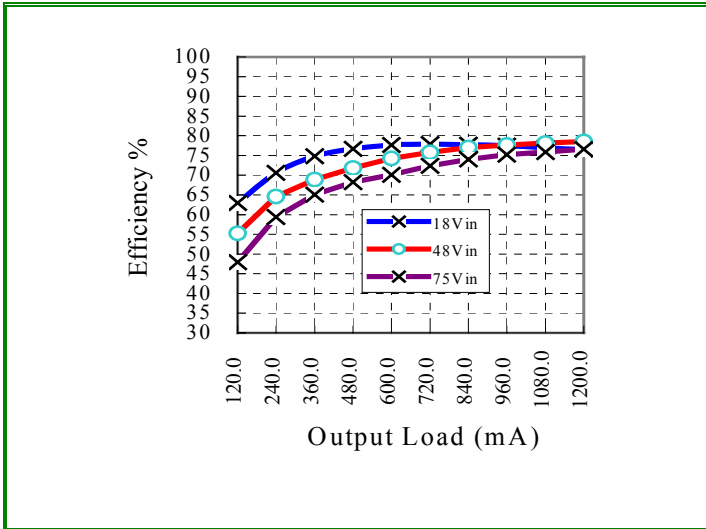

Efficiency vs. Load @ +25° Ambient, ASA01F36-L

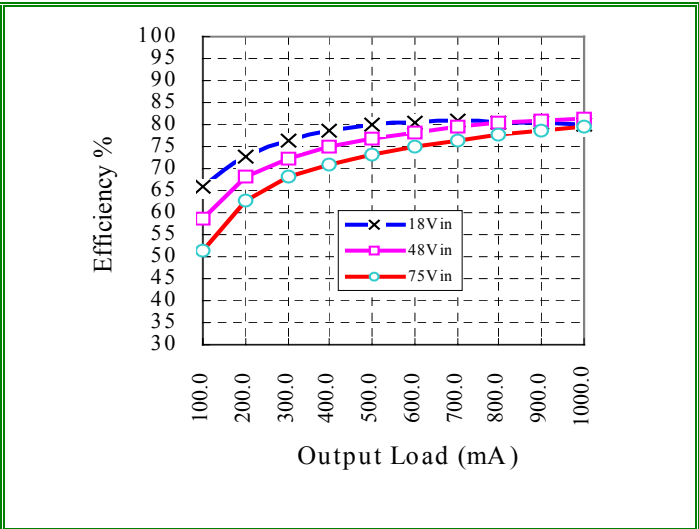

Efficiency vs. Load @ +25° Ambient, ASA01A36-L

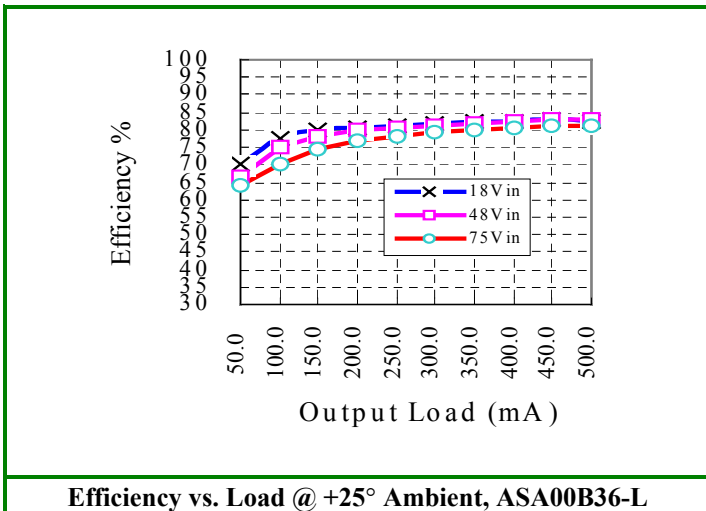

Efficiency vs. Load @ +25° Ambient, ASA00B36-L

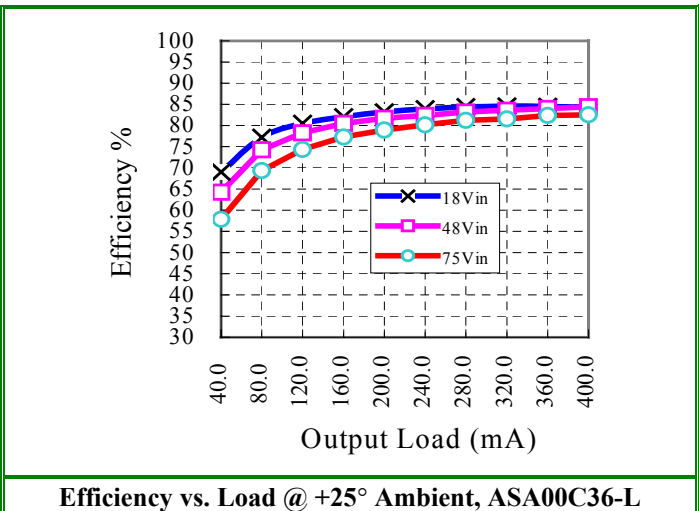

Efficiency vs. Load @ +25° Ambient, ASA00C36-L



Technical Reference Note ASA (6W) Family

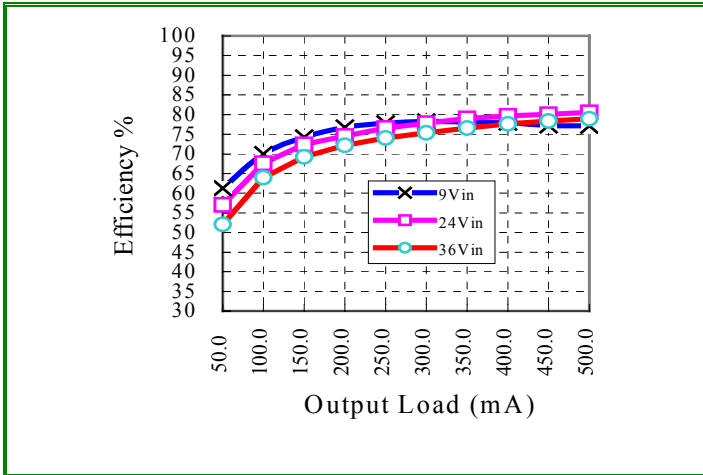

Efficiency vs. Load @ +25° Ambient, ASA00AA18-L

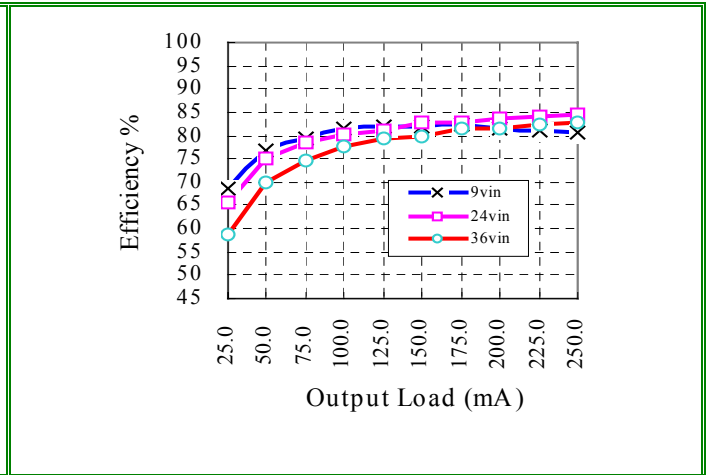

Efficiency vs. Load @ +25° Ambient, ASA00BB18-L

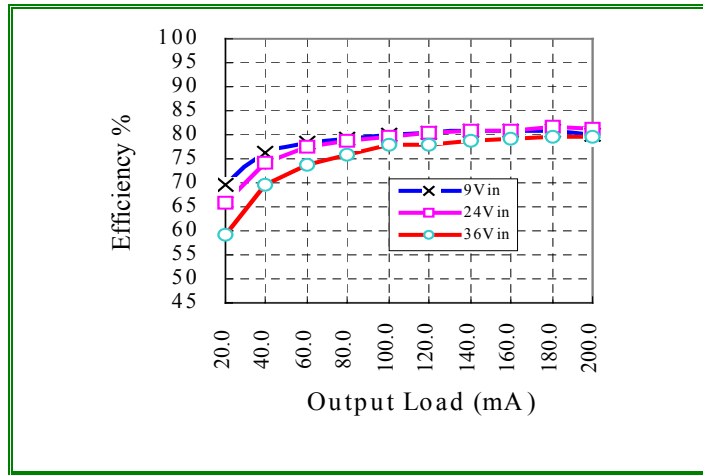

Efficiency vs. Load @ +25° Ambient, ASA00CC18-L

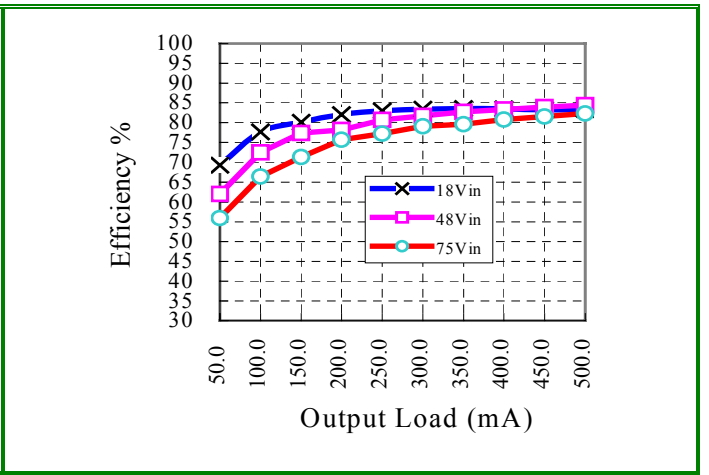

Efficiency vs. Load @ +25° Ambient, ASA00AA36-L



Technical Reference Note ASA (6W) Family

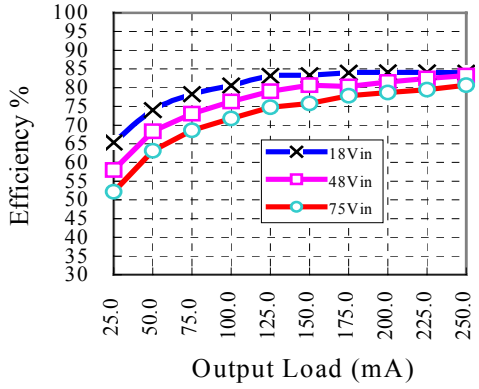

Efficiency vs. Load @ +25° Ambient, ASA00BB36-L

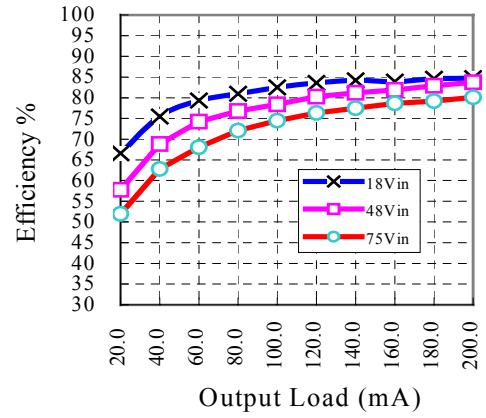

Efficiency vs. Load @ +25° Ambient, ASA00CC36-L

Performance Curves

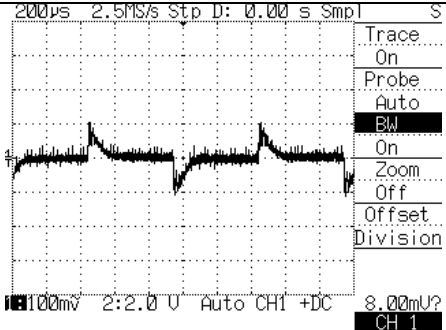
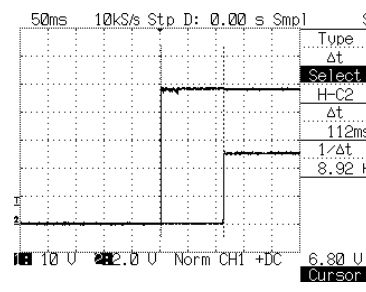
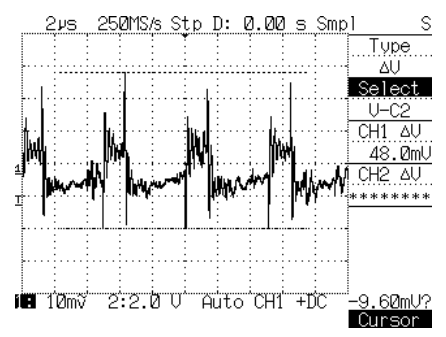
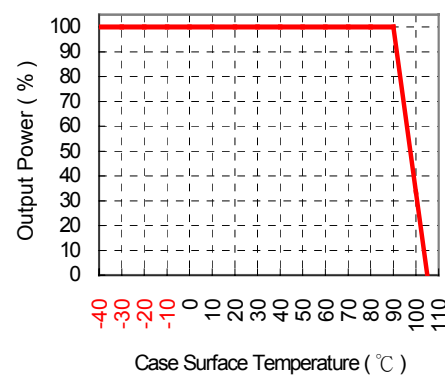
	
<p>Transient Response – 50% to 100% load (ASA01A36-L)</p>	<p>Start-Up Time (ASA01A36-L)</p>
	
<p>Ripple & Noise (ASA01A36-L)</p>	<p>Power Derating</p>



Technical Reference Note ASA (6W) Family



Conducted EMI Performance

```

EUT : Converter                               Power: 24Vdc
-----
M/N: ASA01A18-L                             Test mode : FULL LOAD
-----
POL: LINE      ENGINEER : AGUN      Temp: 24.1      Humidity : 55%
-----
  
```

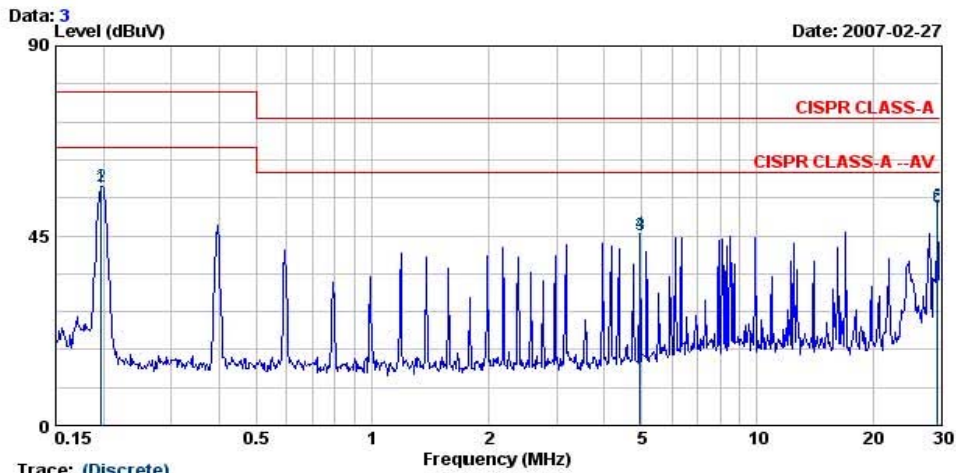

Trace: (Discrete)

Freq. MHz	LISN Factor dB	Cable Loss dB	Meter Reading dBuV	Measured Level dBuV	Limits dBuV	Over Limits dBuV	Detector
0.198	9.80	0.05	46.37	56.22	79.00	-22.78	QP
0.198	9.80	0.05	46.75	56.60	66.00	-9.40	AVERAGE
4.957	9.82	0.24	34.97	45.03	73.00	-27.97	QP
4.957	9.82	0.24	35.35	45.41	60.00	-14.59	AVERAGE
29.544	10.09	0.27	41.66	52.02	73.00	-20.98	QP
29.544	10.09	0.27	41.49	51.85	60.00	-8.15	AVERAGE



Technical Reference Note ASA (6W) Family



EUT : Converter Power: 24Vdc
 M/N: ASA01A18-L Test mode : FULL LOAD
 POL: NEUTRAL ENGINEER : AGUN Temp: 24.1 Humidity : 55%

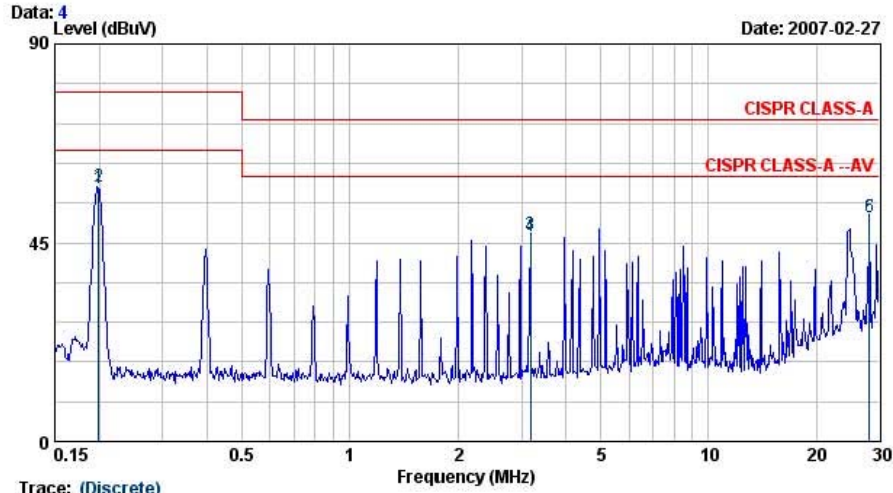

Trace: (Discrete)

Freq. MHz	LISN Factor dB	Cable Loss dB	Meter Reading dBuV	Measured Level dBuV	Limits dBuV	Over Limits dBuV	Detector
0.199	9.80	0.05	47.37	57.22	79.00	-21.78	QP
0.199	9.80	0.05	47.69	57.54	66.00	-8.46	AVERAGE
3.173	9.87	0.10	36.91	46.87	60.00	-13.13	AVERAGE
3.173	9.87	0.10	36.56	46.52	73.00	-26.48	QP
28.158	110.06	0.37	40.25	50.69	73.00	-22.31	QP
28.158	110.06	0.37	40.22	50.66	60.00	-9.34	AVERAGE

Mechanical Dimensions and Module Pin Assignment

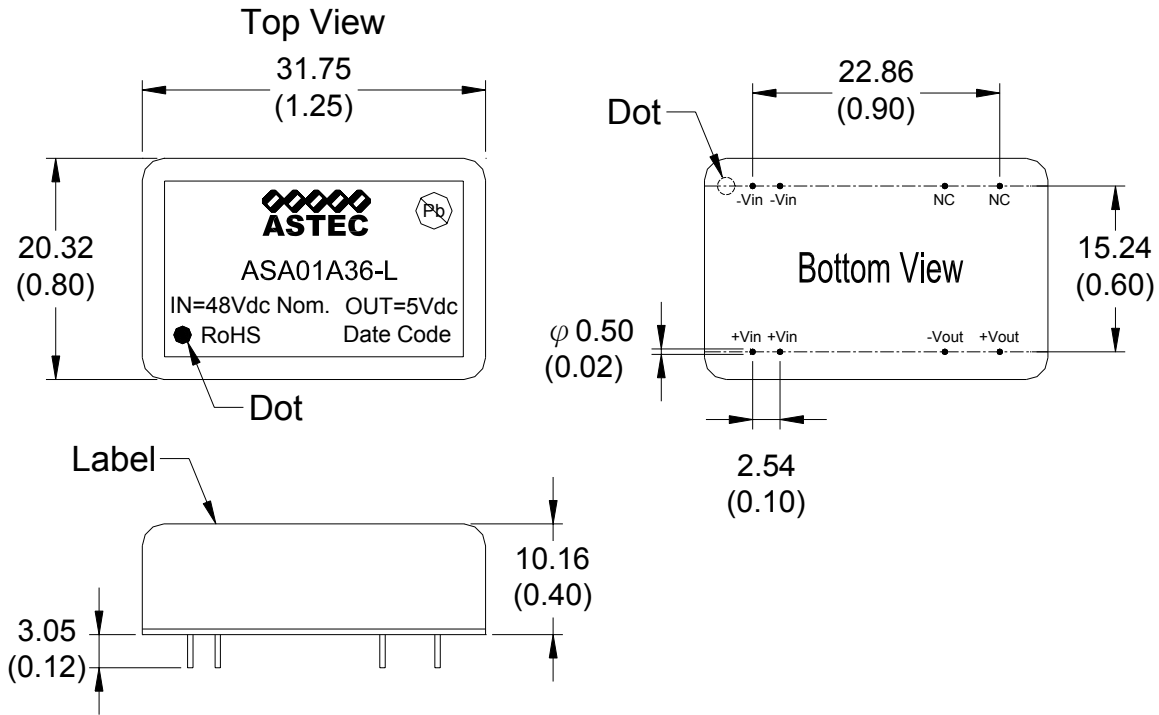

Outline Drawing for ASA Single Series

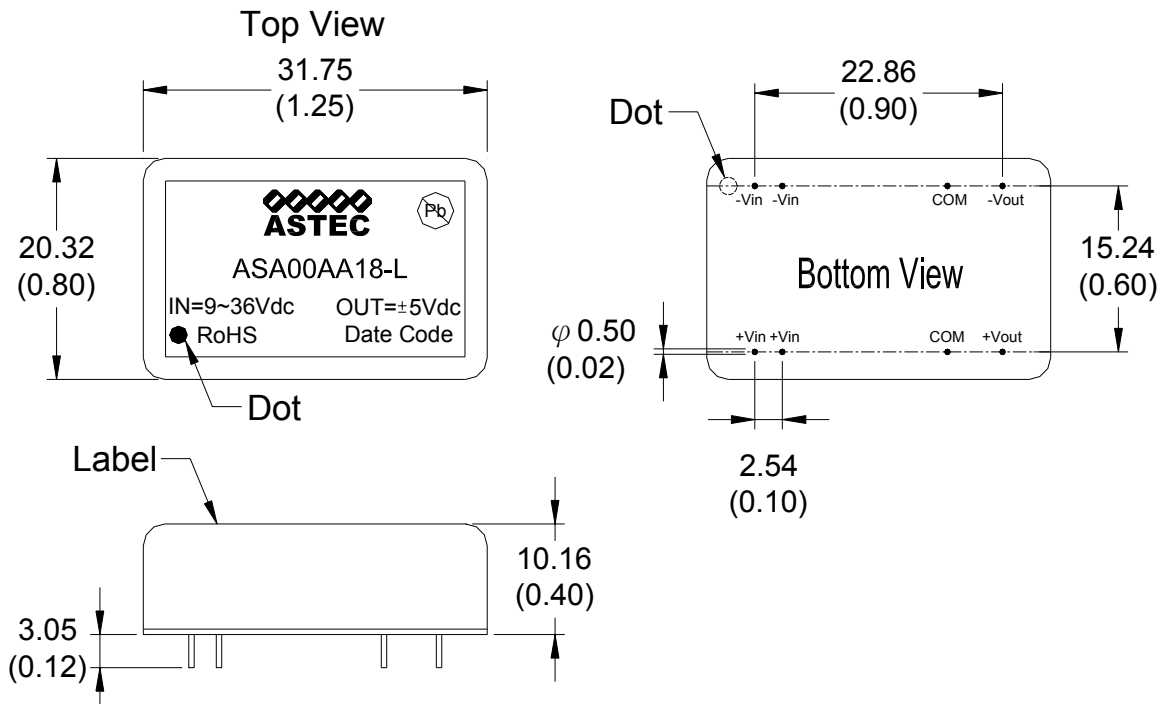

Outline Drawing for ASA Dual Series

Package Information

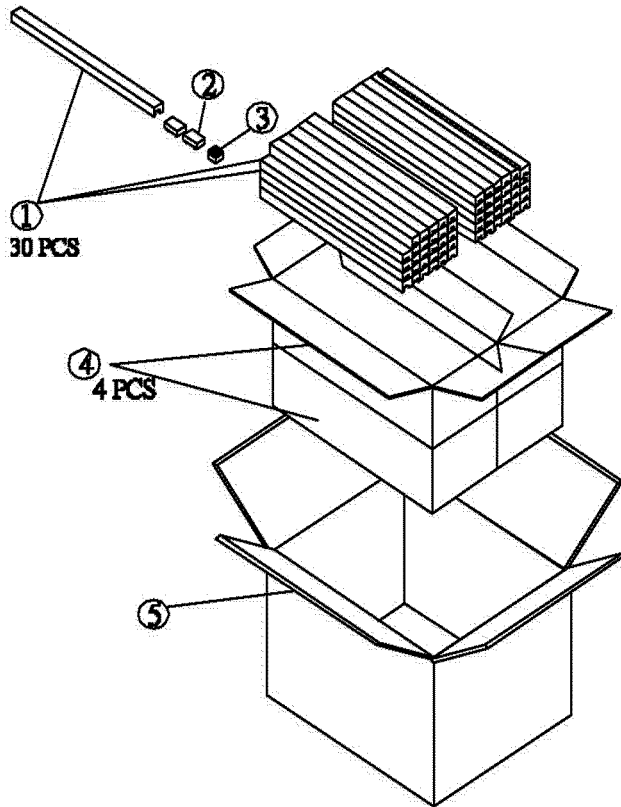

1. PACKING TUBE: 345*22.2*16.7mm ; ONE TUBE = 10 PCS
2. PRODUCTS: ASA SERIES
3. STOPPER
4. INNER CARTON: 388*159*263mm
ONE INNER CARTON = 30 TUBES = 300PCS
5. OUTER CARTON: 405*334*263mm
ONE OUTER CARTON = 4 INNER CARTONS = 1200PCS

STANDARD TOLERANCE LIMITS UNLESS OTHER SPECIFIED.	
RANGE	TOLERANCE
>0~3	±0.10
>3~6	±0.15
>6~30	±0.18
>30~120	±0.20

Recommended Lead-Free Wave Soldering Temperature Profile

