

Lithium Ion Battery Charger for Solar-Powered Systems CN3083

General Description:

The CN3083 is a complete constant-current /constant voltage linear charger for single cell Li-ion and Li Polymer rechargeable batteries. The device contains an on-chip power MOSFET and eliminates the need for the external sense resistor and blocking diode. An on-chip 8-bit ADC can adjust charging current automatically based on the output capability of input power supply, so CN3083 is ideally suited for solar powered system. Furthermore, the CN3083 is specifically designed to work within USB power specifications. Thermal feedback regulates the charge current to limit the die temperature during high power operation or high ambient temperature. The regulation voltage is internally fixed at 4.2V with 1% accuracy, it can also be adjusted with an external resistor. The charge current can be programmed externally with a single resistor. When the input supply is removed, the CN3083 automatically enters a low power sleep mode , dropping the battery drain current to less than 3uA. Other features include undervoltage lockout, automatic recharge, battery temperature sensing and charging/termination indicator. The CN3083 is available in a thermally enhanced 8-pin SOP package.

Applications:

- Solar Powered System
- Digital Still Cameras
- MP3 Players
- Bluetooth Applications
- Portable Devices
- Chargers

Features:

- On-chip 8-bit ADC can adjust charging current automatically based on the output capability of input power supply
- Suitable for Solar-Powered System
- On-chip Power MOSFET
- No external Blocking Diode or Current Sense Resistors Required
- Preset 4.2V Regulation Voltage with 1% Accuracy, adjustable with an external resistor
- Precharge Conditioning for Reviving Deeply Discharged Cells and Minimizing Heat Dissipation During Initial Stage of Charge
- Continuous Programmable Charge Current Up to 600mA
- Constant-Current/Constant-Voltage Operation with Thermal Regulation to Maximize Charge Rate Without Risk of Overheating
- Automatic Low-Power Sleep Mode When Input Supply Voltage is Removed
- Status Indication for LEDs or uP Interface
- C/10 Charge Termination
- Automatic Recharge
- Battery Temperature Sensing
- Available in SOP8 Package
- Pb-free Available

Pin Assignment

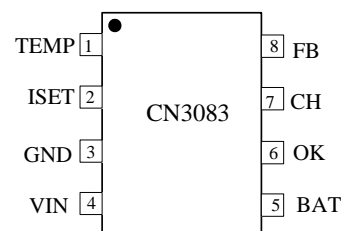

CONSONANCE

Typical Application Circuit

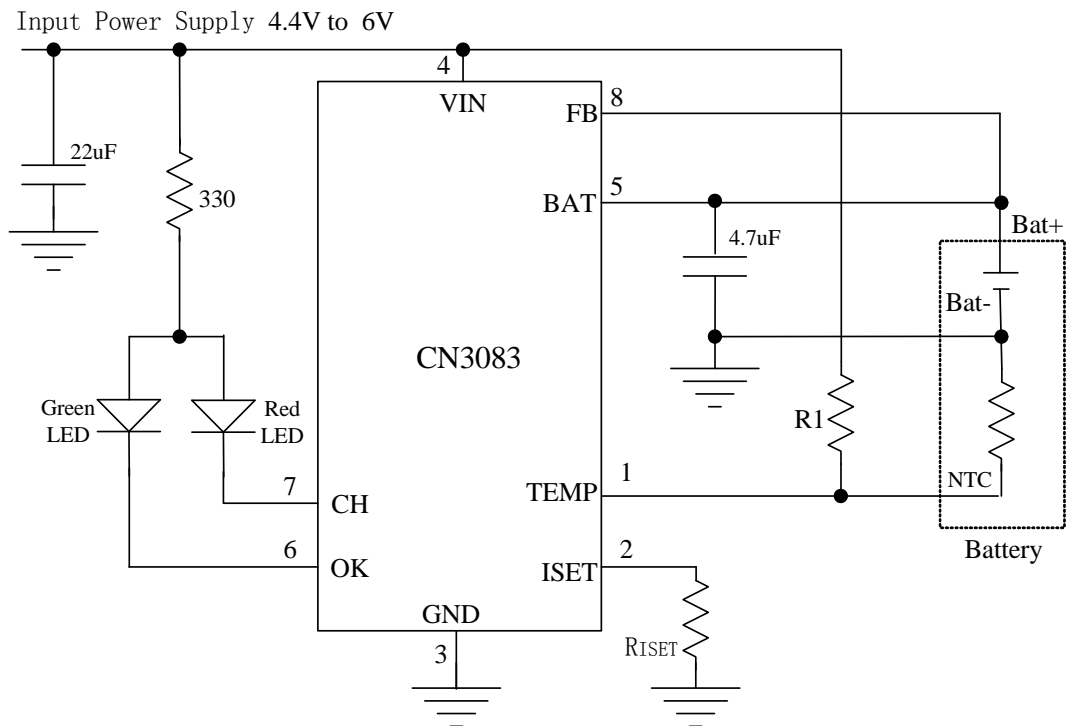

Figure 1 Typical Application Circuit(Constant Voltage Level 4.2V)

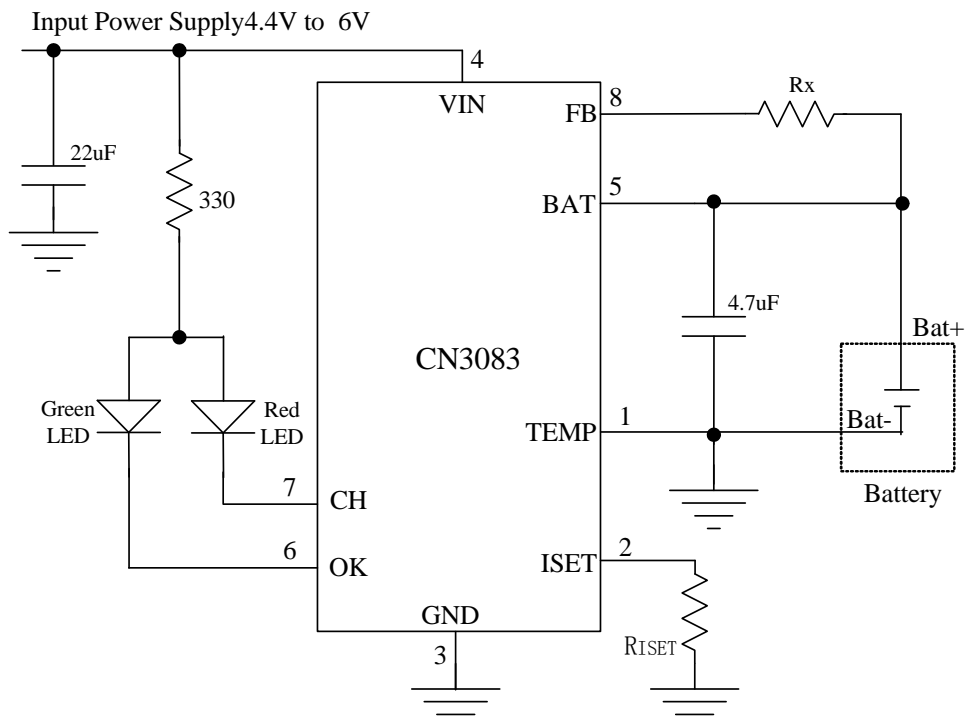

Figure 2 Application Circuit(Adjust Constant Voltage Level with Rx)

In Figure 2, the BAT pin's voltage in constant voltage mode is given by the following equation:

$$V_{bat} = 4.2 + 3.04 \times 10^{-6} \times R_x$$

Where, V_{bat} is in volt

R_x is in ohm

Block Diagram

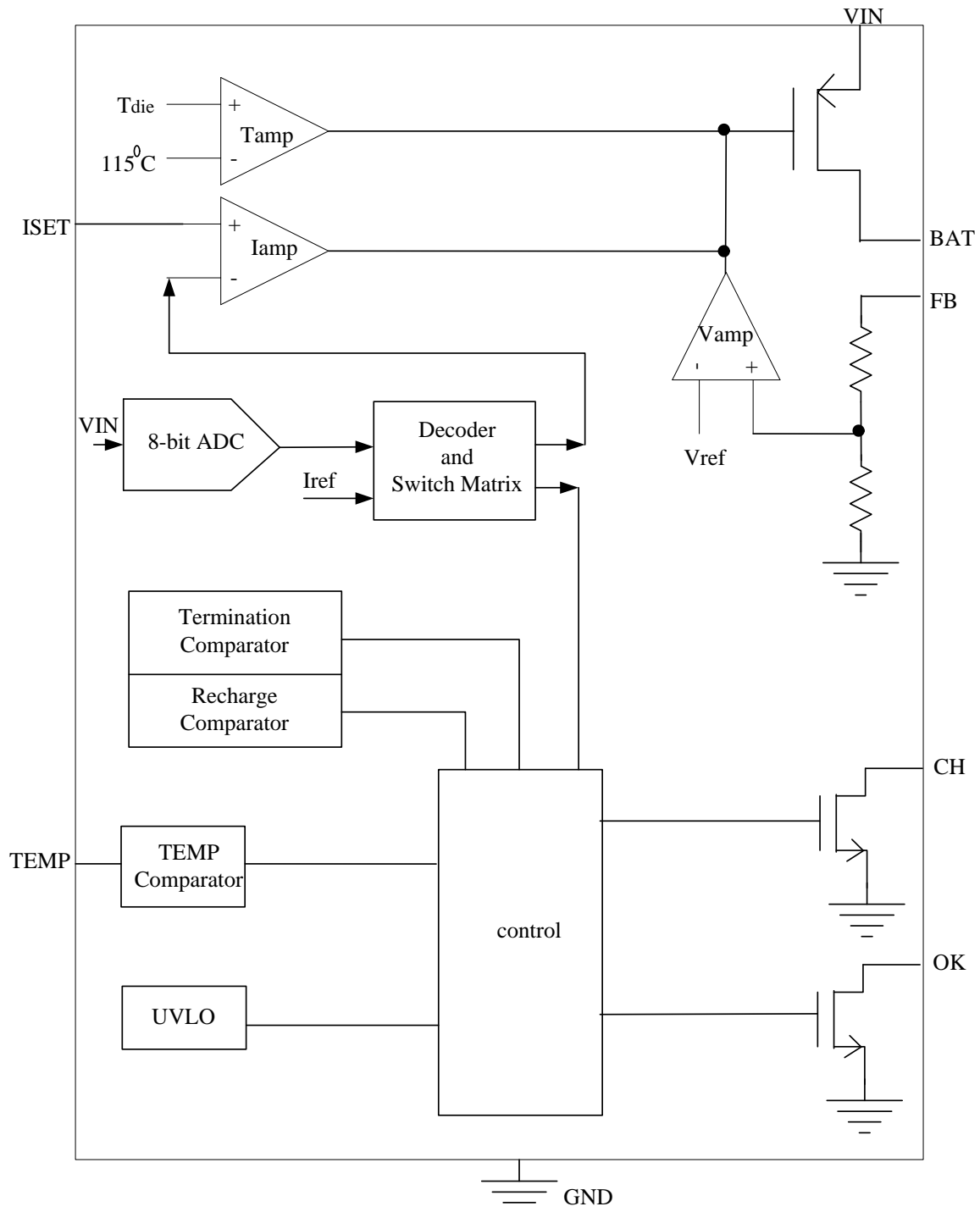

Figure 3 Block Diagram

Pin Description

Pin No.	Name	Function Description
1	TEMP	<p>Temperature Sense Input. Connecting TEMP pin to NTC thermistor's output in Lithium ion battery pack. If TEMP pin's voltage is below 46% of input supply voltage V_{IN} for more than 0.15S, this means that battery's temperature is too high or too low, charging is suspended. If TEMP's voltage level is above 46% of input supply voltage for more than 0.15S, battery fault state is released, and charging will resume.</p> <p>The temperature sense function can be disabled by grounding the TEMP pin.</p>
2	ISET	<p>Constant Charge Current Setting and Charge Current Monitor Pin. The charge current is set by connecting a resistor R_{ISET} from this pin to GND. When in precharge mode, the ISET pin's voltage is regulated to 0.2V. When in constant charge current mode, the ISET pin's voltage is regulated to 2V. In all modes during charging, the voltage on ISET pin can be used to measure the charge current as follows:</p> $I_{CH} = (V_{ISET} / R_{ISET}) \times 900$
3	GND	Ground Terminal.
4	VIN	<p>Positive Input Supply Voltage. V_{IN} is the power supply to the internal circuit. When V_{IN} drops to within 40mv of the BAT pin voltage, CN3083 enters low power sleep mode, dropping BAT pin's current to less than 3uA.</p>
5	BAT	<p>Battery Connection Pin. Connect the positive terminal of the battery to BAT pin. BAT pin draws less than 3uA current in chip disable mode or in sleep mode. BAT pin provides charge current to the battery and provides regulation voltage of 4.2V.</p>
6	OK	<p>Open-Drain Charge termination Status Output. In charge termination status, OK is pulled low by an internal switch; Otherwise OK pin is in high impedance state.</p>
7	CH	<p>Open Drain Charge Status Output. When the battery is being charged, the CH pin is pulled low by an internal switch, otherwise CH pin is in high impedance state.</p>
8	FB	<p>Battery Voltage Kelvin Sense Input. This Pin can Kelvin sense the battery voltage; Also the regulation voltage in constant voltage mode can be adjusted by connecting an external resistor between FB pin and BAT pin.</p>

Absolute Maximum Ratings

All Terminal Voltage..... -0.3V to 6.5V
 BAT Short-Circuit Duration.....Continuous
 Storage Temperature..... -65°C to 150°C
 Lead Temperature(Soldering).....300°C

Maximum Junction Temperature.....150°C
 Operating Temperature..... -40°C to 85°C
 Thermal Resistance (SOP8).....TBD

Stresses beyond those listed under 'Absolute Maximum Ratings' may cause permanent damage to the device. These are stress ratings only and functional operation of the device at these or any other conditions above those indicated in the operational sections of the specifications is not implied. Exposure to Absolute Maximum Rating Conditions for extended periods may affect device reliability.

Electrical Characteristics

(VIN=5V, TA=−40°C to 85°C, Typical Values are measured at TA=25°C, unless otherwise noted)

Parameters	Symbol	Test Conditions	Min	Typ	Max	Unit
Input Supply Voltage	VIN		4.4		6	V
Operating Current	I _{VIN}	Charge Termination Mode	400	650	950	uA
Undervoltage Lockout	V _{uvlo}	VIN falling		3.7	3.9	V
Undervoltage Lockout Hysteresis	H _{uvlo}			0.1		V
Regulation Voltage	V _{REG}	Constant Voltage Mode	4.158	4.2	4.242	V
BAT pin Current	I _{BAT}	R _{ISET} =3.6K, V _{BAT} =3.6V	400	500	600	mA
		R _{ISET} =3.6K, V _{BAT} =2.4V	25	50	75	
		V _{BAT} =V _{REG} , standby mode	1.75	3.5	7	uA
		VIN=0V, sleep mode			3	
Precharge Threshold						
Precharge Threshold	V _{PRE}	Voltage at BAT pin rising	2.9	3.0	3.1	V
Precharge Threshold Hysteresis	H _{PRE}			0.1		V
Charge Termination Threshold						
Charge Termination Threshold	V _{term}	Measure voltage at ISET pin	0.18	0.22	0.26	V
Recharge Threshold						
Recharge Threshold	V _{RECH}			V _{REG} −0.1		V
Sleep Mode						
Sleep Mode Threshold	V _{SLP}	V _{IN} from high to low, measures the voltage (V _{IN} −V _{BAT})		40		mv
Sleep mode Release Threshold	V _{SLPR}	V _{IN} from low to high, measures the voltage (V _{IN} −V _{BAT})		90		mv
ISET Pin						
ISET Pin Voltage	V _{ISET}	Precharge mode		0.2		V
		Constant current mode		2.0		
TEMP PIN						
Input Threshold	V _{TEMP}		43.5	46	48.5	%V _{IN}
TEMP input Current		TEMP to V _{IN} or to GND			0.5	uA
OK Pin						
OK Sink Current	I _{OK}	V _{OK} =0.3V, termination mode		10		mA
OK Leakage Current		V _{OK} =6V, charge mode			1	uA
CH Pin						
CH Sink Current	I _{CH}	V _{CH} =0.3V, Charge status		10		mA
CH Leakage Current		V _{CH} =6V, termination mode			1	uA

Detailed Description

The CN3083 is a linear battery charger designed primarily for charging single cell lithium-ion or lithium-polymer batteries. Featuring an internal P-channel power MOSFET, the charger uses a constant-current/constant-voltage to charge the batteries. Continuous charge current can be programmed up to 600mA with an external resistor. No blocking diode or sense resistor is required. The on-chip 8-bit ADC can adjust charging current automatically based on the output capability of input power supply, so CN3083 is ideally suited for the solar-powered systems, or the applications that need to charge lithium-ion battery or lithium polymer battery with an input power supply whose output capability is limited. The open-drain output OK and CH indicates the charger's status. The internal thermal regulation circuit reduces the programmed charge current if the die temperature attempts to rise above a preset value of approximately 115°C. This feature protects the CN3083 from excessive temperature, and allows the user to push the limits of the power handling capability of a given circuit board without risk of damaging the CN3083 or the external components. Another benefit of adopting thermal regulation is that charge current can be set according to typical, not worst-case, ambient temperatures for a given application with the assurance that the charger will automatically reduce the current in worst-case conditions.

The charge cycle begins when the voltage at the V_{IN} pin rises above the UVLO level, a current set resistor is connected from the ISET pin to ground. The CH pin outputs a logic low to indicate that the charge cycle is ongoing. At the beginning of the charge cycle, if the voltage at FB pin is below 3V, the charger is in precharge mode to bring the cell voltage up to a safe level for charging. The charger goes into the fast charge constant-current mode once the voltage on the FB pin rises above 3V. In constant current mode, the charge current is set by R_{ISET} . When the battery approaches the regulation voltage, the charge current begins to decrease as the CN3083 enters the constant-voltage mode. When the current drops to charge termination threshold, the charge cycle is terminated, OK is pulled low by an internal switch and CH pin assumes a high impedance state to indicate that the charge cycle is terminated. The charge termination threshold is 10% of the current in constant current mode. To restart the charge cycle, just remove the input voltage and reapply it. The charge cycle can also be automatically restarted if the FB pin voltage falls below the recharge threshold. The on-chip reference voltage, error amplifier and the resistor divider provide regulation voltage with 1% accuracy which can meet the requirement of lithium-ion and lithium polymer batteries. When the input voltage is not present, the charger goes into a sleep mode, dropping battery drain current to less than 3uA. This greatly reduces the current drain on the battery and increases the standby time.

The charging profile is shown in the following figure:

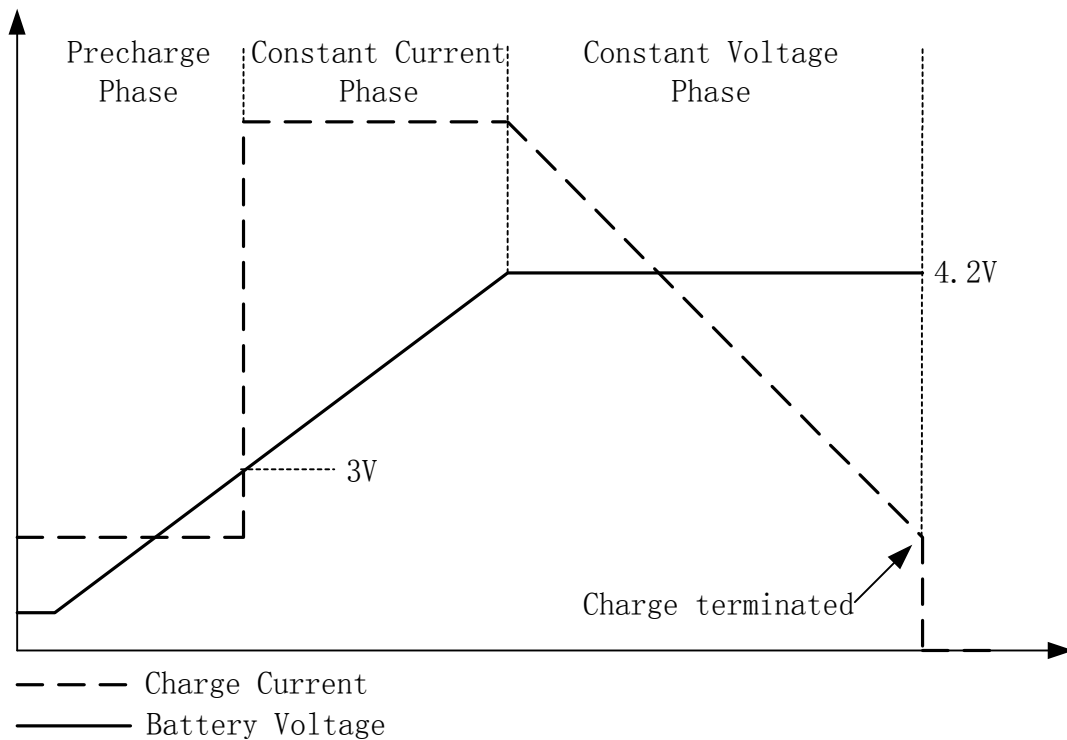

Figure 4 Charging Profile

Application Information

Undervoltage Lockout (UVLO)

An internal undervoltage lockout circuit monitors the input voltage and keeps the charger in shutdown mode until V_{IN} rises above the undervoltage lockout voltage. The UVLO circuit has a built-in hysteresis of 0.1V.

Sleep mode

There is an on-chip sleep comparator. The comparator keeps the charger in sleep mode if V_{IN} falls below sleep mode threshold ($V_{BAT} + 40\text{mV}$). Once in sleep mode, the charger will not come out of sleep mode until V_{IN} rises 90mV above the battery voltage.

Precharge mode

At the beginning of a charge cycle, if the battery voltage is below 3V, the charger goes into precharge mode, and the charge current is 10% of fast charge current in constant current mode.

Charging Current limited by the Output capability of Input Power Supply

If the output capability of input power supply is less than the charging current set by the resistor at ISET pin, then the on-chip 8-bit ADC will begin to function to adjust the charging current based on the output capability of input power supply. In this case, the charging current may be less than the value set by the resistor at ISET pin, but it is maximized to the output capability of input power supply on the condition that the input voltage at VIN pin is no less than 4.35V, which is the minimum operating voltage of CN3083. So the charging current can be set according to the maximum output capability of input power supply, not the worst case.

Adjusting the regulation voltage in constant voltage mode

The regulation voltage in constant voltage mode can be adjusted by an external resistor connecting between FB pin and BAT pin as shown in Figure 5:

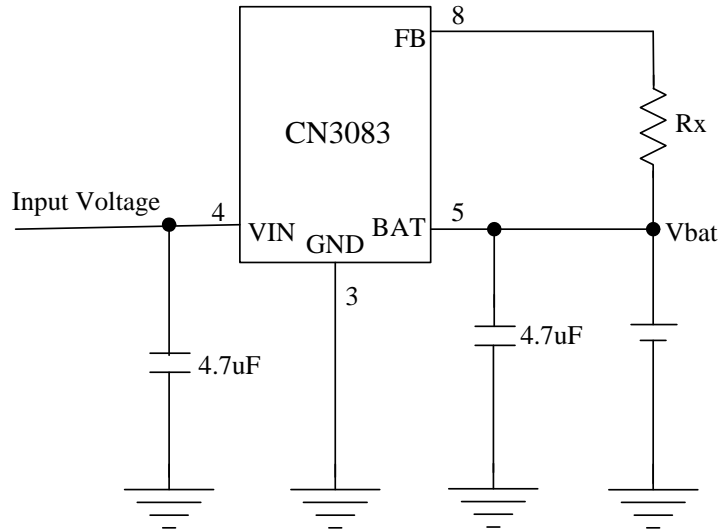

Figure 5 Adjusting Regulation Voltage in Constant Voltage Mode

In Figure 5, the regulation voltage in constant voltage mode will be given by the following equation:

$$V_{bat} = 4.2 + 3.04 \times 10^{-6} \times R_x$$

Where,

V_{bat} is in volt

R_x is in ohm

Programming Charge Current

The formula for the battery charge current in constant current mode is:

$$I_{CH} = 1800V / R_{ISET}$$

Where:

I_{CH} is the charge current in ampere

R_{ISET} is the total resistance from the ISET pin to ground in ohm

For example, if 500mA charge current is required, calculate:

$$R_{ISET} = 1800V / 0.5A = 3.6k \Omega$$

For best stability over temperature and time, 1% metal film resistors are recommended. If the charger is in constant-temperature or constant voltage mode, the charge current can be monitored by measuring the ISET pin voltage, and the charge current is calculated as the following equation:

$$I_{CH} = (V_{ISET} / R_{ISET}) \times 900$$

Combine Two Power Inputs

Although the CN3083 allows charging from a solar power supply, a wall adapter or a USB port can also be used to charge Li-Ion/Li-polymer batteries. Figure 6 shows an example of how to combine 2 power inputs. A P-channel MOSFET, M1, is used to prevent back conducting into the 2nd power supply when the 1st power supply is present and Schottky diode, D1, is used to prevent 2nd power supply loss through the 1k Ω pull-down resistor.

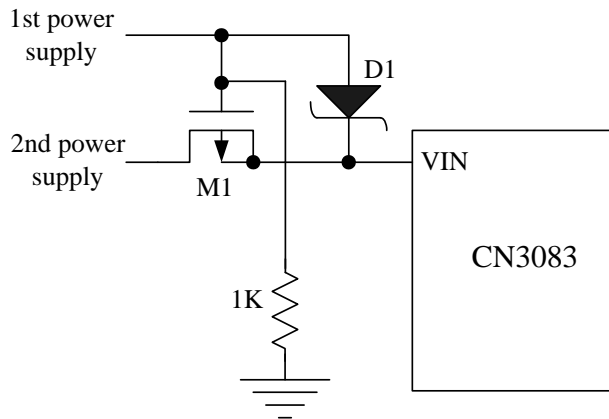

Figure 6 Combining 2 Input Power Supply

Battery Temperature Sense

To prevent the damage caused by the very high or very low temperature done to the battery pack, the CN3083 continuously senses battery pack temperature by measuring the voltage at TEMP pin.

If $V_{TEMP} < (46\% \times V_{IN})$ for 0.15 seconds, it indicates that the battery temperature is too high or too low and the charge cycle is suspended. If $V_{TEMP} > (46\% \times V_{IN})$ for 0.15 seconds, the charge cycle resumes.

The battery temperature sense function can be disabled by connecting TEMP pin to GND.

Recharge

After a charge cycle has terminated, if the battery voltage drops below the recharge threshold of 4.1V, a new charge cycle will begin automatically.

Constant-Current/Constant-Voltage/Constant-Temperature

The CN3083 use a unique architecture to charge a battery in a constant-current, constant-voltage, constant temperature fashion as shown in Figure 3. Amplifiers I_{amp} , V_{amp} , and T_{amp} are used in three separate feedback loops to force the charger into constant-current, constant-voltage, or constant-temperature mode, respectively. In constant current mode the charge current delivered to the battery equal to $1800V/R_{ISET}$. If the power dissipation of the CN3083 results in the junction temperature approaching 115°C , the amplifier T_{amp} will begin decreasing the charge current to limit the die temperature to approximately 115°C . As the battery voltage rises, the CN3083 either returns to constant-current mode or it enters constant voltage mode straight from constant-temperature mode.

Open-Drain Status Outputs

The CN3083 have 2 open-drain status outputs: OK and CK. CH is pulled low when the charger is in charging status, otherwise CH becomes high impedance. OK is pulled low if the charger is in charge termination status, otherwise OK becomes high impedance.

When the battery is not present, the charger charges the output capacitor to the regulation voltage quickly, then the BAT pin's voltage decays slowly to recharge threshold because of low leakage current at BAT pin, which results in a 100mv ripple waveform at BAT pin, in the meantime, CH pin outputs a pulse to indicate that the battery's absence. The pulse's frequency is around 10Hz when a 4.7uF output capacitor is used.

The open drain status output that is not used should be tied to ground.

V_{IN} Bypass Capacitor C_{IN}

Many types of capacitors can be used for input bypassing, C_{IN} is typically a 22uF capacitor.

For the consideration of the bypass capacitor, please refer to the Application Note AN102 from our website.

Stability

Typically a 4.7uF capacitor from BAT pin to GND is required to stabilize the feedback loop.

In constant current mode, the stability is also affected by the impedance at the ISET pin . With no additional capacitance on the ISET pin, the loop is stable with current set resistors values as high as 50K Ω . However, additional capacitance on ISET pin reduces the maximum allowed current set resistor. The pole frequency at ISET pin should be kept above 200KHz. Therefore, if ISET pin is loaded with a capacitance C, the following equation should be used to calculate the maximum resistance value for R_{ISET} :

$$R_{ISET} < 1 / (6.28 \times 2 \times 10^5 \times C)$$

In order to measure average charge current or isolate capacitive load from ISET pin, a simple RC filter can be used on ISET pin as shown in Figure 7.

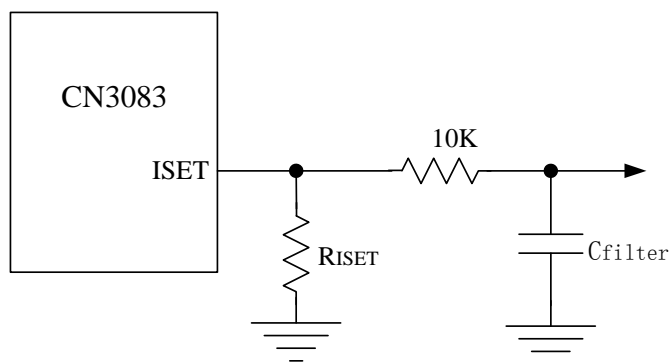

Figure 7 Isolating Capacitive Load on ISET Pin

Board Layout Considerations

1. R_{ISET} at ISET pin should be as close to CN3083 as possible, also the parasitic capacitance at ISET pin should be kept as small as possible.
2. The capacitance at VIN pin and BAT pin should be as close to CN3083 as possible.
3. During charging, CN3083's temperature may be high, the NTC thermistor should be placed far enough to CN3083 so that the thermistor can reflect the battery's temperature correctly.
4. It is very important to use a good thermal PC board layout to maximize charging current. The thermal path for the heat generated by the IC is from the die to the copper lead frame through the package lead (especially the ground lead) to the PC board copper, the PC board copper is the heat sink. The footprint copper pads should be as wide as possible and expand out to larger copper areas to spread and dissipate the heat to the surrounding ambient. Feedthrough vias to inner or backside copper layers are also useful in improving the overall thermal performance of the charger. Other heat sources on the board, not related to the charger, must also be considered when designing a PC board layout because they will affect overall temperature rise and the maximum charge current.

The ability to deliver maximum charge current under all conditions require that the exposed metal pad on the back side of the CN3083 package be soldered to the PC board ground. Failure to make the thermal contact between the exposed pad on the backside of the package and the copper board will result in larger thermal resistance.

Package Information

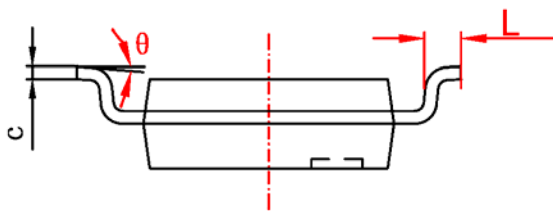
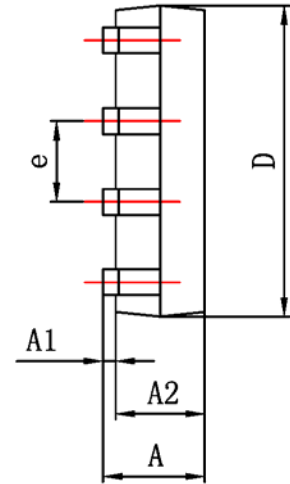
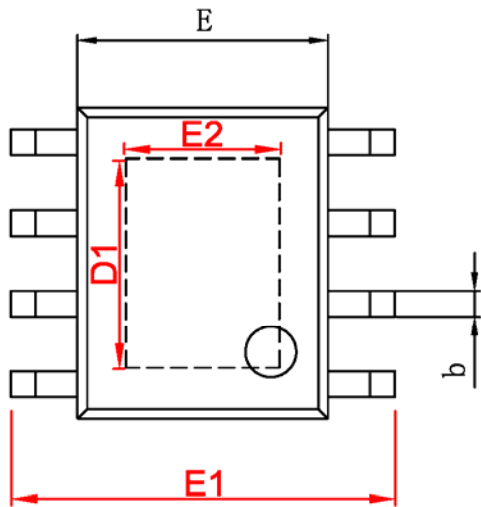

字符	Dimensions In Millimeters		Dimensions In Inches	
	Min	Max	Min	Max
A	1.350	1.750	0.053	0.069
A1	0.050	0.150	0.004	0.010
A2	1.350	1.550	0.053	0.061
b	0.330	0.510	0.013	0.020
c	0.170	0.250	0.006	0.010
D	4.700	5.100	0.185	0.200
D1	3.202	3.402	0.126	0.134
E	3.800	4.000	0.150	0.157
E1	5.800	6.200	0.228	0.244
E2	2.313	2.513	0.091	0.099
e	1.270 (BSC)		0.050 (BSC)	
L	0.400	1.270	0.016	0.050
θ	0°	8°	0°	8°

Consonance does not assume any responsibility for use of any circuitry described. Consonance reserves the right to change the circuitry and specifications without notice at any time.